

ALLIANCE SENSORS GROUP

A DIVISION OF H.G. SCHAEVITZ LLC

SC-200 *Signal Conditioner Module for AC-LVDTs, RVDTs, LVRTs, and Half-bridges*

Setup and Operating Instructions



Alliance Sensors Group
7300 US Rt.130 North, Bldg. 22
Pennsauken, NJ 08110 USA
www.alliancesensors.com

P/N 5700-0016, Rev R8 6-1-2024

EU CE Declaration of Conformity

The undersigned, representing **Alliance Sensors Group, a Division of H. G. Schaevitz, LLC, 7300 US Rt.130 North, Bldg. 22, Pennsauken, NJ 08110 USA**

hereby declares that the product, **Model SC-200 LVDT Signal Conditioner Module,**

of the following category and type: **Measurement, Control Equipment, and Laboratory Use,**

is in conformity with the provisions of the following EU CE directives: **EMC Directive 2014/30/EU; RoHS 2 Directive 2011/65/EU**

Testing was done to requirements as stated in harmonized standards **EN 61326-1: 2013: Emissions, Clause 7.2; CISPR 11: 2009, A-1: 2010, Radiated Emissions, Grp 1, Class A; EN 61326-1: 2013: Radiated Immunity, Table 1. EN 50581: 2012: Assessment of Electronic Products Re: RoHS**

using the methods noted hereafter: **IEC 61000-4-2: 2008, Electrostatic Discharge
IEC 61000-4-3: 2006, A-1: 2007, A2: 2010 Immunity
IEC 61000-4-8: 2009 Power Frequency Magnetic Fields.**

A TCF for the product is maintained for inspection at the location noted.

Edward E. Herceg

Edward E. Herceg, VP, CTO

Oct 1, 2018

Date of Issue

Product Warranty

Alliance Sensors Group warrants the Model SC-200 LVDT Signal Conditioner to be free from defects in workmanship and materials for a period of two (2) years from the date of shipment. In the event a valid claim is made under this warranty, the only obligation of Alliance Sensors Group is to repair or replace the unit. ***Under no circumstances will Alliance Sensors Group be liable for fitness of purpose by the user or any damages, direct, consequential, or otherwise, or for any damage to any sensor connected to the SC-200 LVDT Signal Conditioner, or for any damage to any electronic equipment connected to the inputs or outputs of the SC-200 LVDT Signal Conditioner.***

To submit a claim under the provisions of this warranty, the claimant must secure an RMA (Returned Material Authorization) number by contacting Alliance Sensors Group at: 856-727-0250, or by sending a letter, or by e-mailing sales@alliancesensors.com. The defective unit must be returned freight prepaid to Alliance Sensors Group for inspection, accompanied by the RMA number and a letter of explanation of the purported defect. If the inspection and evaluation validates the warranty claim, the repaired or a replacement unit will be promptly returned to the claimant freight prepaid.

If inspection and evaluation of the device determines that it has been misused, abused, misapplied, or modified by the user; has been subjected to a fire, flood, or mishandling; or is damaged due to improper packing for the return shipment, no warranty claim will be allowed or accepted. Instead, the unit will be returned to the claimant freight collect, along with an invoice for the evaluation charge.

Any questions about Alliance Sensors Group's warranty provisions can be answered by contacting Alliance Sensors Group at: 856-727-0250, or by sending an e-mail query to: sales@alliancesensors.com.

PREFACE

In this manual, you will find a chart on page 4 for quickly connecting your AC-LVDT, AC-RVDT, LVRT, or inductive half-bridge sensor to this model SC-200 DIN-rail mounting, 24 Volt DC-operated signal conditioning module, and a **Quick Start Guide** on page 5 for calibrating it with the two front-panel push buttons, which eliminate any need for external pot adjustments. The internal DSP (Digital Signal Processor) will lead you through the various calibration steps by means of the three green LEDs on the module's front panel, as illustrated on page 2. The term *LVDT* is used generically throughout these instructions for any low voltage audio frequency AC-operated position sensors, i.e. LVDTs, RVDTs, LVRTs, and inductive half-bridges.

You will also find the SC-200 specifications and a detailed description of the advanced functions available for applications where you may wish to go beyond the basic features. Such possibilities include the master / slave synchronization of the excitation for multiple LVDTs, an open-collector failure warning switch output, the DC voltage null position indicator signal, and digital communications via the RS-485 addressable multi-drop port. The SC-200 also incorporates a settings locking feature for enhanced cybersecurity by preventing and displaying any attempts at tampering with the module. The SC-200 LVDT Signal Conditioner module is **CE** compliant for both EMI and RoHS. To assure long, maintenance-free life, all inputs and outputs are ESD protected, along with protection against reverse voltage, overvoltage, and short circuits. Operating and power-on inrush current are also limited by solid-state resettable fuses.

TABLE of CONTENTS

Identification of Front Panel LEDs and Switch Functions	2
Identification of DIP Switches and I/O connections	3
LVDT Wiring Configurations	4
Quick Start Guide	5
Functional Description of the SC-200	6
DC Power Input	6
LVDT Primary Excitation	6
Inductive Half-Bridge Connections	6
Master/Slave Synchronization	6
LVDT Output Signal	7
DC Output Filtering	7
Failure and Fault Indicators	7
RS-485 Communications	7
Expanded Calibration Procedure	8
Terminology and Definitions	8
Calibration Procedure	8
Null Point Location	8
Null Indicator Output	9
Setting Full Scale Output Point	9
Setting Zero Output Point	9
Alternative Calibration Procedure	10
Live Zero and Extra-range Outputs	10
Using the Voltage and Current Outputs	10
Failure Diagnostics	11
Failure Warning Output Signals	11
Troubleshooting LVDT Connections	12
Grounding and Shielding	12
Commands for the RS-485 Port	12
End point Recalibration	14
Hot Swapping Modules	14
Replacing an SC-100 Module with an SC-200 Module	14
Specifications and Module Dimensions	15
Appendix A: Error Codes and Fault Matrix	16
Appendix B: Cybersecurity Features of the SC-200 Module	17
Appendix C: DIP Switch Settings Table for Decimal Digital Addresses	17

Identification of Front Panel LEDs and Switch Functions

(Use with *Quick Start Guide* on page 5)

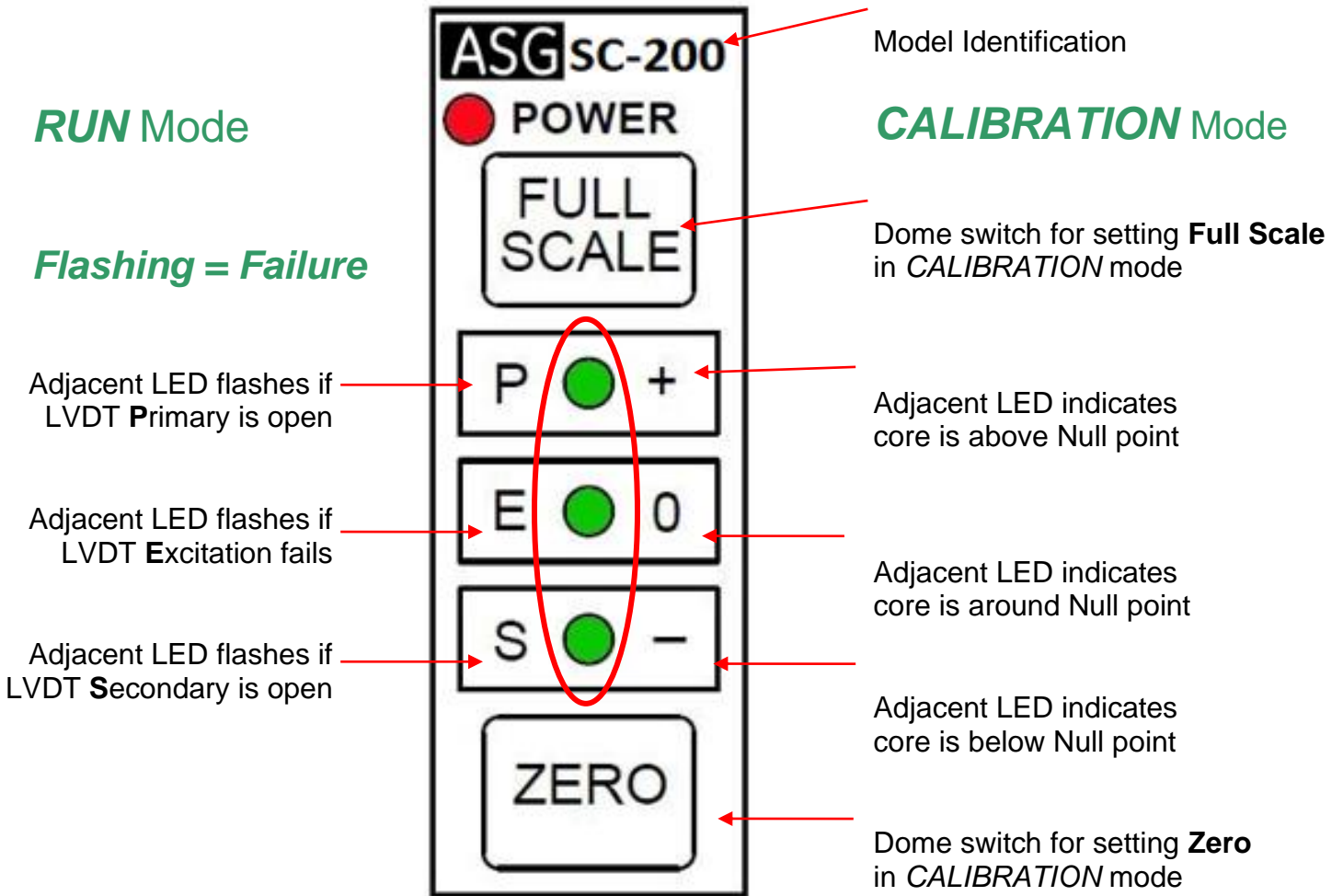

Figure 1 SC-200 front panel with calibration pushbuttons and LEDs to show Null point and LVDT failures

DIP switch functions & I/O connections (Use with Quick Start Guide on page 5)

Excitation Frequency	2.5 kHz	5 kHz	7.5 kHz	10 kHz	DIP Switch State	OFF	ON
DIP switch DS2-1	ON	OFF	OFF	ON	DIP switch DS2-3	Normal Output	Inverted Output
DIP switch DS2-2	OFF	ON	OFF	ON	DIP switch DS2-4	No LF Filtering	LF LP Filter ON

Table 1 DS-2 Excitation Frequency Settings.

Table 1a DS2 Analog Output Modifier Settings.

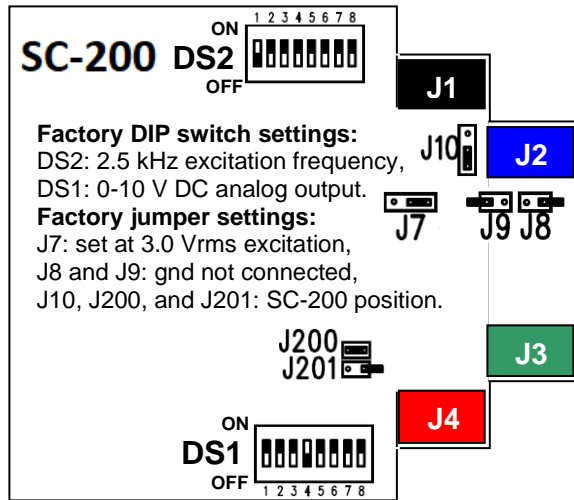

DIP Switch DS2-No.	5	6	7	8
DIP Switch ON to Add	8	4	2	1

Table 1b Digital Address Setting Schema; DS2 Switches **5, 6, 7, 8**: Factory Set **OFF**. A Table of DIP Switch Settings for Decimal Digital Addresses is in **Appendix C**, Pg. 17.

All factory DIP switch settings are in **bold**.

DS-1 and DS-2 DIP switch settings are also shown on the left side label of module case.

Figure 2 SC-200 DIP Switch and Jumper Locations

DS1 Position	1	2	3	4	5	6	7	8
Output with DS1-No. ON	0 to 5 Volts	1 to 5 Volts	0.5 to 4.5 Volts	0 to 10 Volts	-10 to +10 Volts	0.5 to 9.5 Volts	0 to 20 mA	4 to 20 mA

Table 2 DS1 Analog Output Settings; only one switch is allowed to be set ON, all others must be set OFF

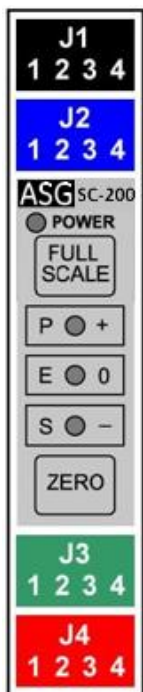

Figure 3 Front View

J1-1	Black	LVDT Primary High or Half-bridge High End
J1-2	Black	LVDT Primary Low or Half-bridge Low End
J1-3	Black	LVDT Secondary Low (Ground if J10 is set in half-bridge mode)
J1-4	Black	LVDT Secondary High or Half-bridge Mid-tap
J2-1	Blue	LVDT Secondaries Junction Point (Shield Ground if J9 is ON)
J2-2	Blue	Failure Warning Output (Open Collector Switch, 50 mA max.)
J2-3	Blue	-15 V DC input for ±10 V DC output (Shield Ground if J8 is ON)
J2-4	Blue	Sync Input / Output (Master / Slave Bus)
J3-1	Green	RS-485 Data Line (D +)
J3-2	Green	RS-485 Data Line (D -)
J3-3	Green	Analog Output Ground (Common Ground)
J3-4	Green	Analog Output (+) (Voltage or Current, as selected with DS1)
J4-1	Red	Null Indicator Differential DC Output (floating)
J4-2	Red	Null Indicator Differential DC Output (floating)
J4-3	Red	Power Ground (Common Ground)
J4-4	Red	Power Input (+) (15 to 30 V DC)

Table 3 SC-200 LVDT Signal Conditioner Module I/O Connections
 Note: J3-3 and J4-3 share the same Common Ground; use only one ground connection to prevent potential ground loops

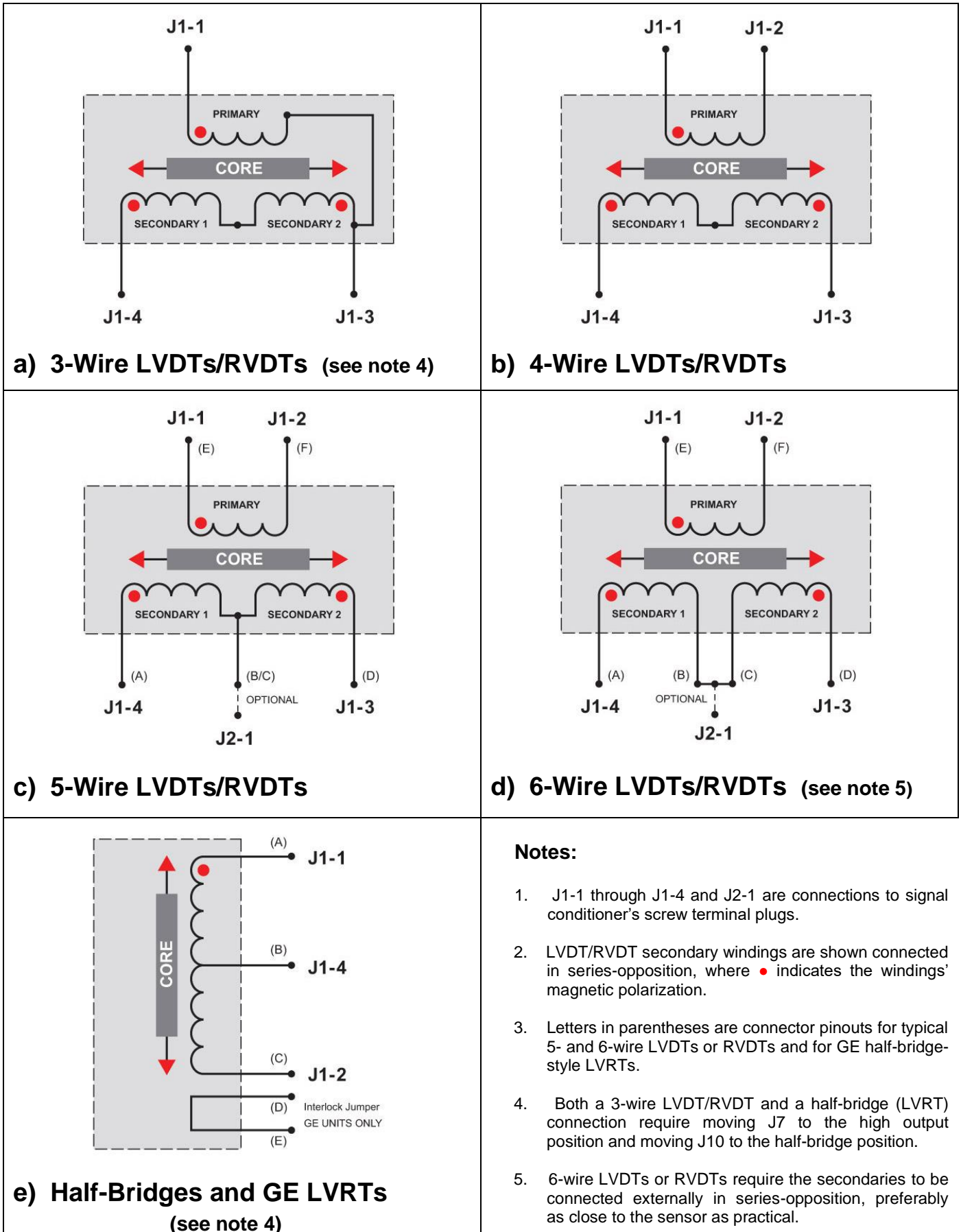

Figure 4 LVDT or RVDT and Half-Bridge (LVRT) Wiring Connections to SC-200 Signal Conditioner

Quick Start Guide for SC-200 LVDT Signal Conditioner

1. Default Settings: The SC-200 factory default LVDT excitation frequency is 2.5 kHz, which works for most LVDTs, and the default DC output is 0 to 10 Volts. If you can utilize the default settings for excitation frequency and DC output, skip to Step 3. If not, open the SC-200's case by pushing the locking tab inward on both of the thin sides and sliding the case rearward to expose the two circuit-board-mounted DIP switches, DS1 and DS2.

2. Set the pcb-mounted DIP switches: LVDT excitation frequency can be changed by setting DS2-1 and DS2-2 according to the left side label or Table 1 on page 3. The DC output can be changed by setting DS1 on the pc board according to the left side label or Table 2 on page 3. When all DIP switch changes are finished, slide the pc board back into the module's case on its internal tracks and snap the two sections of the case back together.

3. Mount the module: Remove the color-coded plugs from the SC-200 module and install the module on the DIN rail by hooking the bottom of the module's rear edge under the bottom edge of the rail, and then pressing the module back against the rail until the spring-loaded rail catch engages the top edge of the rail. To remove the module from the DIN rail, insert a flat-bladed screwdriver into the slot in the metal catch at the top rear of the module, lift the catch upward, and disengage the module from the rail.

4. Make the I/O connections: Following the connections on the right side label or in Table 3 on page 3, and the schematics of Figure 4 on page 4, connect the color-coded screw-terminal plugs at least to the LVDT's primary and secondaries (and the secondaries' junction point if needed), to DC power, and to the input of the PLC, control system, or analog output indicator. Never ground J1-1 or J1-2 (black plug) because that will short out part of the excitation voltage. Connections to a failure alarm or the master/slave bus can also be made at this time. When finished, insert the colored plugs completely back into their corresponding colored jacks on the module.

5. Calibrate the LVDT's core positions: Turn on the DC power and allow the module to warm up for at least 15 minutes before beginning the calibration procedure. The red **POWER** LED should glow steadily and the green LEDs should be off, except the **P** LED will be steady on if the module is a master (*refer to page 6*) or is operating stand-alone. If any of the other green LEDs are on or flashing, see Appendix A and check all the connections. Calibration cannot proceed if there is an error being displayed. With power applied, the red **POWER** LED on, and no errors being displayed by the green LEDs, LVDT calibration can proceed. **Note:** *The LVDT's core must not protrude from the LVDT at any point during the calibration process or an erroneous calibration will result.*

▶ Shift the module into *CALIBRATION* mode by simultaneously depressing both the **FULL SCALE** and **ZERO** buttons for 3 seconds until the red **POWER** LED begins flashing. The module is now in *CALIBRATION* mode

▶ One of the green LEDs will be illuminated, indicating that the LVDT's core is on one side or the other of null, or at null. As the LVDT's core is moved inward, that LED will go out and the middle LED will come on (showing the LVDT is at null), then the middle LED will go out and the LED on the opposite end (compared to the first green LED that was on) will come on. Adjust the LVDT core's position until the middle green LED is on. The LVDT's core is now approximately at its null or mid-range position.

▶ Move the workpiece whose position is being measured so that it is located at the middle of its range of motion when the LVDT's core is at its null position. Mechanically couple the LVDT core to the workpiece in this position. Now, move the workpiece to the desired Full Scale (maximum travel) position and depress the **FULL SCALE** pushbutton until the green (+) LED flashes once and the (-) LED lights up.

▶ Next, move the workpiece, still coupled to the LVDT's core, to the Zero (start of travel) position at the other end of its range of motion and depress the **ZERO** pushbutton until the green (-) LED flashes once.

▶ If one (or both) of the green LEDs is still flashing, rerun the calibration procedure by moving the workpiece and the coupled core to the end position indicated by the flashing LED and depressing its nearby button. The red LED should be flashing, showing that the module is in *CALIBRATION* mode. To return to *RUN* mode, depress both the **FULL SCALE** and the **ZERO** buttons simultaneously for about 3 seconds until the green LEDs go out and the red **POWER** LED turns on steady. Verify that the analog output and its directional sense (slope) is that which was desired. If the analog output slope is reversed, interchange primary connections or switch DS2-3 *on*.

Functional Description of the SC-200 LVDT Signal Conditioner

The SC-200 is an intelligent LVDT Signal Conditioner module which uses a DSP to sequence and control the module's various functions. The following descriptions can help a user set up and apply this module.

DC Power Input

The input power range of +15 to +30 V DC covers the common +24 V DC industrial power supply and the older ± 15 V DC. For a ± 10 Volt output, +15 V DC is input to J4-4, -15 V DC is connected to J2-3, and ground to J4-3. If the input voltage rises above 32 V, a TVS shunt diode conducts and a PTC resettable fuse will open if the current becomes too high. After cooling, the fuse will reclose to allow normal functioning to resume. The SC-200 module avoids a high inrush current with an NTC current limiting device in series with the power circuitry. The module's input is also protected against reverse polarity connection and ESD.

LVDT Primary Excitation

The AC-LVDT's primary is excited by a digitally synthesized low distortion sine wave signal. The nominal excitation frequency selections are 2.5, 5, 7.5, or 10 kHz. The sine wave synthesizer operates from a crystal oscillator, so the resulting frequencies will be very stable. 2.5 kHz is chosen as the factory default setting, since most commercial LVDTs specify 2500 to 3300 Hz excitation and will operate very satisfactorily at this frequency. To select another excitation frequency, it is necessary to open the SC-200 module's case and change the setting of DIP switches DS2-1 and DS2-2 according to the left side label or Table 1 on page 3. The excitation frequency can also be selected by **Set Exf** command over the RS-485 bus. (See page 12)

The amplitude of the excitation sine wave is very stable. The excitation driver operates in push-pull mode to provide about 3 Volts ACrms to the LVDT's primary, but for specific cases, the drive voltage can be raised by 50% by removing internal jumper J7, or decreased by 50% by exciting the primary single ended to ground (using J1-1 and J2-1 with a jumper on J9). A fault detector in a SC-200's LVDT excitation circuitry detects if the LVDT's primary is open, shorted, or disconnected. If so, the green **P** or **E** LED on the front panel flashes, a failure warning is output at J2-2, and an error code shows on the RS-485 bus.

Inductive Half-Bridge Connections

An AC inductive half-bridge sensor, or LVRT, is very similar to an LVDT, but combines an LVDT's primary winding with a center-tapped secondary winding. AC excitation is applied to the ends of the winding and the output signal is taken from the mid-tap. Before hooking up a half-bridge or LVRT sensor to the SC-200 move internal jumper J10 from its default position over to half-bridge position, and set J7 for high output. Connect the high end of the half-bridge winding to terminal J1-1, the low end to terminal J1-2, and the mid-tap to terminal J1-4. See Figure 4e on page 4. The module will now operate the same as it does for an LVDT and will offer the same fault indications as are displayed for a failure of the windings of an LVDT.

Master/Slave Synchronization

When multiple LVDTs and their interconnecting wiring operate in close proximity, beat frequencies often occur due to slight differences in the excitation frequencies of the modules. A beat frequency is seen as a very low frequency amplitude modulation of the modules' DC output. To prevent such an interaction, each module's excitation must be synchronized to the same frequency. For the SC-200, one module is chosen as a master and the other modules operate as slaves synced to the master over the auto-mastering sync bus.

The modules' auto-master syncing can be implemented as follows: First, all modules must have their excitation DIP switches DS2-1 and DS2-2 set for the same nominal excitation frequency. Second, each module must have a different unit address, which can be set from 00 through 15 by DIP switches DS2-5, DS2-6, DS2-7, and DS2-8 according to the left side label or **Appendix C**. The default address, 00, is usually applied to the master module. Finally, terminal J2-4 of the master module is connected to terminal J2-4 of up to fifteen slave modules, and all modules must share the same common ground. All the sync connections are protected against ESD or erroneous connections. If the master oscillator fails, a new master is automatically developed to produce the excitation oscillator frequency, providing true fail/safe operation. If all the modules are not powered up at the same time, the module with the lowest numerical address at initial power up will become the master, as indicated by its **P** LED being steady *on*. For a stand alone SC-200 module with no slaves, the **P** LED also will be steady *on* in *RUN* mode because it is a master.

LVDT Output Signal

The two secondaries of the LVDT are connected together in series-opposing to develop a differential signal. This LVDT output circuit also has a built-in fault detector to warn if the secondaries are open-circuited, not connected together, shorted to ground, or the cable is disconnected. Any fault or wiring failure in the secondaries flashes the green **S** LED on the module's front panel, triggers a failure warning output at J2-2, and shows an error code on the RS-485 bus.

The differential signal from the LVDT's secondaries is demodulated, buffered, and then sent to a 12-bit analog-to-digital converter (A/D) built into the DSP. The amplitude of full scale LVDT output signals accepted extends from 50 mVrms to 5 Vrms, a 40 dB dynamic range. The DSP scales the digital data as needed for the output type that is selected. The digital data are converted back to an analog signal by a digital-to-analog converter (DAC). This analog signal is passed to a buffer/driver stage from which the signal is then delivered as one of the eight user-selectable analog DC outputs: 0 to 5 V, 1 to 5 V, 0.5 to 4.5 V, 0.5 to 9.5 V, 0 to 10 V, -10 to +10 V, 0 to 20 mA, and 4 to 20 mA. The output is chosen by setting one position of 8-section DIP switch DS-1 inside the module to *on* using Table 2, or by the **Set Aout** RS-485 command. (See page 12). The factory default analog output is 0 to 10 V DC (DS1-4 *on*). All unipolar analog outputs feature a "live zero", whereby the output can go below zero so that a user can establish a true zero point.

Besides selecting the specific analog output signal desired, a user can invert the output signal by setting DIP switch DS2-3 to *on*, effectively reversing the slope of the output signal. For example, inverting the 4-to-20 mA output changes it to 20-to-4 mA over exactly the same range of motion for the LVDT's core.

DC Output Filtering

Within the DSP, the digitized demodulated LVDT signal goes through some digital filtering before being input to the DAC. The DAC's analog output is first sent to a two-pole low pass R/C filter having a -3 dB cutoff frequency of at least 10% of the excitation frequency set by DS2-1 and DS2-2, and then on to the output terminals. For applications requiring very low noise and ripple, the analog output can further filtered by turning DIP switch DS2-4 *on*, which engages an additional single-pole low pass filter with a -3 dB cutoff frequency that can be programmed between 0.1 to 10 Hz (default) by using the **Set LF** RS-485 command.

Failure and Fault Indicators

The green front panel LEDs will flash to indicate failures in the cases of an open LVDT primary (**P**), an open LVDT secondary (**S**), or a loss of excitation (**E**). The DSP determines a loss-of-excitation condition exists if anything causes the digital signal to the sine wave synthesizer to be lost. Any of these faults will trigger the failure warning output, an open collector transistor switch that pulls the failure warning output terminal J2-2 either low or high (NO or NC) for any case where the DSP detects a fault or failure. The failure warning output terminal includes protections against overcurrent, overvoltage, and ESD. Page 11 and Table 6 offer more detailed explanations of the LED indications and the failure warning outputs.

RS-485 Communications

The SC-200 incorporates an RS-485 two-wire multi-drop serial communications interface for up to 16 devices. This port enables half-duplex serial communications to implement specific ASCII commands listed later in this manual by which a module can be setup and calibrated, and system data can be read and stored on a PC. The PC should be running an ASCII terminal program such as Hyper Terminal and using a 2-wire RS-485 converter for a serial or USB port to connect to SC-200 module terminals J3-1 and J3-2. See page 12 for details about setting up the RS-485 communications link and the ASCII commands available.

In the future ASG expects to have a Graphic User Interface (GUI) program to communicate with SC-200 via the RS-485 multi-drop com link available for download from the ASG website: www.alliancesensors.com. The proposed GUI will facilitate setting up, calibrating, and monitoring any SC-200 on the 2-wire RS-485 multi-drop network from a remote computer or terminal, as well as saving system-specific configuration data in files which could be reloaded into another SC-200 module during a hot swap. If all the SC-200 signal conditioners for a particular application (up to 16 modules) were to be connected to the RS-485 multi-drop network which could then be connected to a wireless RS-485 interface with appropriate third party hardware and software, it would then permit signal conditioner calibration or configuration from a remote location.

Expanded Version of the SC-200 Calibration Procedure

Terminology and Definitions

To provide a clear explanation of the operation of this product, it is necessary to properly define the following words: *program*, *setup*, and *calibration*. To understand this manual and module, the word *program* is used to describe the operating system resident within the DSP, which is factory loaded and is not accessible to the user. The word *setup* is used to describe the settings chosen by the factory or the user for the LVDT's excitation frequency, analog DC output, and other parameters that can be selected either by the internal DIP switches or via commands using the RS-485 communications port. *Setup* should be done in accordance with the **Quick Start Guide** and the DIP switch settings on page 3. Besides the switches for excitation frequency and analog output, there are choices for additional low pass filtering to improve signal-to-noise ratio, inversion of output slope, and up to 16 individual RS-485 digital addresses.

The word *calibration* is used to describe a process or sequence of actions by which the range of motion of the workpiece is matched to the range of motion of the LVDT to produce the desired electrical output from the system. To begin, the LVDT's body is clamped in place. Next, the LVDT's core is moved to find its Null point or mid-range position. The LVDT's null point is the only repeatable unique position of the core; for most LVDTs, there is no definable *full scale* or *zero* position. The workpiece is moved to the middle of its range of motion and then, without changing the core's position, the two are mechanically coupled to each other. The LVDT core and connected workpiece are moved to the Full Scale or maximum travel position so the module's *Full Scale Output* can be set. Finally, the LVDT core and connected workpiece are moved to the Zero or starting point (minimum) position, where the module's *Zero Output* is set. The result of this process is a typical end-point calibration for the LVDT-based position measuring system.

Calibration Procedure

Before beginning the calibration procedure, allow the module to warm up for at least 15 minutes. On the front panel, there are three green LEDs positioned vertically and a red LED for power indication. The **POWER** LED normally glows steadily when power is applied and the signal conditioner module is in its *RUN* mode. When the module is in *RUN* mode (not in *CALIBRATION* mode), the green LEDs are on or flash to indicate failures, but in master/slave or standalone operation, the **P** LED on the master module will glow steadily. If the LEDs indicate a failure, calibration cannot proceed until the failure is corrected. When in *CALIBRATION* mode, the green LEDs indicate the position of the LVDT's core relative to its null point. To enter *CALIBRATION* mode, depress the **FULL SCALE** and **ZERO** buttons together until the red **POWER** LED starts flashing, indicating the module is now in *CALIBRATION* mode. The module can also be put into *CALIBRATION* mode by the **Cal** command via the RS-485 port. (See page 12 for the RS-485 commands).

Null Point Location

After entering *CALIBRATION* mode from *RUN* mode, as described above, it is possible to find the LVDT's null point by moving the core and watching the green LEDs. In *CALIBRATION* mode, the three green LEDs operate according to Table 4 below as followings: if the core is far into LVDT's positive side (above null), only the uppermost (+) LED will glow. This means the core should be moved in the direction expected to be toward null. As the core approaches the null point, the center (0) LED will light (at null). If the movement of the core is continued (below null) in the same direction, then the bottom (-) LED will glow. In this way, an LVDT's core can be positioned sufficiently close to the LVDT sensor's mid-range position for reasonably accurate calibration. **Note:** *The LVDT's core must not protrude from the LVDT during any null point measurement or else false null indications can result.*

Core Above Null (+)	Core At Null (0)	Core Below Null (-)
●	○	○
○	●	○
○	○	●

Table 4 Finding an LVDT's null in *CALIBRATION* mode: LED state vs. LVDT core position

Null Indicator Output

During *CALIBRATION*, the green front-panel LEDs are used to show the position of the LVDT's core in relation to its Null point. To find the Null point with better resolution, or for a continuous Null indication, connect an ungrounded DC voltmeter between terminals J4-1 and J4-2, the Null Indicator output. With the LVDT's core at Null, each terminal is floating at about 1.5 V DC above common ground, so the voltmeter will read zero volts between the terminals. As the LVDT's core is moved off Null, one terminal's voltage increases toward +3 V as the other terminal's voltage goes toward -3 V, or vice versa when moving the core in the other direction, for a maximum voltmeter reading of approximately ± 3 Volts DC. *The LVDT's core must not protrude from the LVDT during any null point measurement or false null readings can result.*

Setting the Full Scale Output Point

Once the LVDT core's Null position has been found and the core has been mechanically connected to the object whose motion is being measured, the next step is to calibrate the Full Scale output of the measuring system. This step assumes that the range of motion is symmetrical with respect to the LVDT's null point, but the process can work for asymmetrical measuring ranges, as long as the Full Scale and Zero points are no closer to each other than 10% of the sensor's full scale. This step assumes the module's Full Scale output was selected during the initial setup by setting DIP switch DS1 according to Table 2. Note that asymmetrical calibration could result in increased noise in the output due to bit flipping.

The red **POWER** LED should be flashing, indicating the unit is still in *CALIBRATION* mode. The core with its attached workpiece must be moved to the desired Full Scale (maximum travel) position. Once the core is in the Full Scale position, depress the **FULL SCALE** button on the front panel until the upper green LED below the **FULL SCALE** button flashes once, or send an **FS** command via the RS-485 port. The LED flash indicates that the Full Scale position calibration has been accepted. If an error occurred and it is desired to set the Full Scale again, depress the **FULL SCALE** button again and the Full Scale calibration will be updated with this new position as indicated by another flash of the upper green LED.

Setting the Zero Output Point

When the Full Scale calibration is complete, the lower green LED above the **ZERO** push button will start flashing. Move the core with its attached workpiece to the Zero (travel start) position. Then depress the **ZERO** button until the lower green LED flashes once, or send a **Z** command via the RS-485 port. The flash of the LED indicates that the Zero position calibration has been accepted. If an error occurred and it is desired to set the Zero point again, depress the **ZERO** button again and the Zero point calibration will be updated with the new position as indicated by another flash of the lower green LED.

Full Scale is set	Full Scale set required	Zero set required	Zero is set
●	☼	○	○
○	○	○	○
○	○	☼	●

Table 5 LEDs in *CALIBRATION* mode. LEDs flash if Full Scale reset or Zero reset is required.

If the LVDT's calibration was successful and the DSP was able to be properly scaled, then the green LEDs will not be blinking. In the event that something unusual has caused the calibration to be rejected (such as a very high or very low output LVDT), either the upper (FULL SCALE) or lower (ZERO) LED, or both, may be flashing again. This means that the core must be moved to that particular position again, and re-scaled or re-zeroed by repeating the original Full Scale and/or Zero calibration procedures. Normally, repeating the calibration process one time will remedy any problems that have developed during the DSP's auto-scaling operations.

When the calibration is completed, exit the *CALIBRATION* mode by depressing both the **FULL SCALE** and **ZERO** buttons simultaneously until the red **POWER** LED stops flashing and glows steadily. There is also an RS-485 command for exiting the *CALIBRATION* mode. After exiting *CALIBRATION* mode, the module will return to normal operation in *RUN* mode, the red **POWER** LED will glow steady, and the green LEDs (except for the master module in a master/slave configuration or a stand-alone) will not be glowing.

Alternative Calibration Procedure

For some specific applications, there is an alternative calibration procedure that can often save time by establishing the mechanical relationship of the LVDT's core to the workpiece whose motion is being measured without going through the process of actually finding the LVDT's null point. This process can work well in cases where the nominal range of the LVDT is at least 10% larger than the range of motion of the workpiece to be measured. It works by connecting an ungrounded DC voltmeter with a range of 0 to ± 3 Volts to terminals J4-1 and J4-2, the Null Indicator Output. (Refer to **Null Indicator Output** on page 9)

Mechanically connect the LVDT core to the workpiece at about the middle of its range of motion. Move the workpiece to each end of its range of motion, noting the voltage indicated on the meter. Adjust the core's position relative to the workpiece so that the magnitude of the output of the voltmeter at each end of the range of motion is approximately the same, which establishes that the LVDT is operating in a symmetrical manner within its nominal range of measurement. Proceed to calibrate the system's Zero and Full Scale as noted on page 9. *The LVDT's core must not protrude from the LVDT during any of the measurements or calibration errors will result*

Live Zero and Extra-range Output

When a unipolar DC output range is selected, the Full Scale and Zero positions correspond exactly to that range. But an SC-200 offers a "live zero" feature, whereby the DC output is able to go higher and lower than these end points by 2.5 to 3%. So, for example, with a 0 - to -10 V full scale output, the output continues to respond past the Full Scale and Zero calibration points, going up to about 10.3 V or down to about -0.3 V. For current loop output, the output extends about 0.4 mA to 0.6 mA past the calibration points. For a 4-to-20 mA output (span = 16 mA), it continues to respond up to 20.6 mA and down to about 3.6 mA. These extra-range values can vary from module to module, depending on circuit and component tolerances.

Using the Voltage and Current Outputs

When using an SC-200 module in a voltage output mode, the output current to the load resistor is normally just a fraction of a milliampere, but it should always be less than 5 mA. The recommended minimum load resistance across terminals J3-4 (+ output) and J3-3 (- ground) for any voltage output is 10,000 Ohms.

If using an SC-200 module's current loop outputs for 0 to 20 mA or 4 to 20 mA, the maximum permissible total loop resistance depends on the power supply voltage, as shown in Figure 5 below. When the module is powered by the recommended 24-Volt DC supply, the maximum loop resistance is 850 Ohms. **Important:** An SC-200 can only output loop current if the module output is connected to a load resistor. Not connecting a loop load will result in the **E** and **S** LEDs flashing and error code **2048**. Typical loop load resistors are 250 or 500 Ohms, so the module has adequate capacity for working with long connecting lines. Because the SC-200's current output is 3-wire sourcing, it should never be connected into a 2-wire loop-powered system.

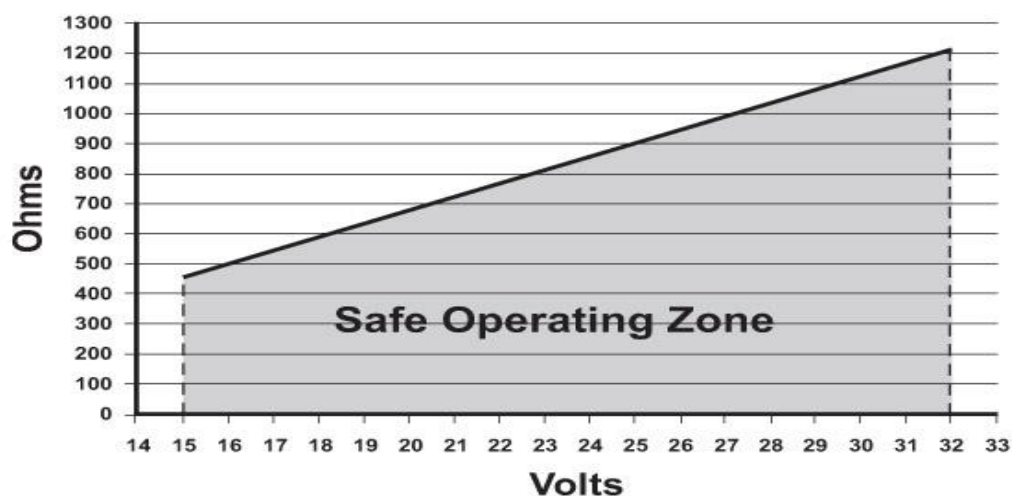

Figure 5 Maximum Loop Resistance vs. Loop Supply Voltage

Failure Diagnostics

The SC-200 module incorporates diagnostics to identify internal failures, mistakes made during the setup, and operational failures due to external causes, and provides both a visual and electrical failure indication. When the SC-200 is in *RUN* mode, the front-panel LEDs indicate specific failures according to Table 6 by the LEDs steady on, by LEDs flashing at a rate of 0.1 second on and 0.1 second off, and by the LEDs alternating between blinking and steady on. In *RUN* mode, the red **POWER** LED is steady on, but in *CAL* mode, it will flash at the slower rate of 0.5 second on and 0.5 second off, which is not a failure warning.

<i>RUN</i> <i>MODE</i>	Normal Operation	Master Operation	Primary Open	Secondary Open	LVDT not Connected	Excitation Error	Shorted Sync	Frequency Set Error	Input Overload	Output Error
POWER	●	●	●	●	●	●	●	●	●	●
P	○	●	⚙	○	⚙	○	○	○	⚙	○
E	○	○	○	○	○	⚙	●	○	●	⚙
S	○	○	○	⚙	⚙	○	○	●	⚙	⚙

Table 6 ⚙ indicates a flashing LED. Most failure modes flash the LEDs, but some LEDs stay steady on.

In addition to the local visual indication of a failure or fault by the LEDs as illustrated in Table 6, the SC-200 also provides electrical outputs that allow the failure warning to be transmitted to a remote indicator, the system controller, or some other device. These electrical outputs include a failure signal using an open collector switch and numerical error codes displayed over the RS-485 bus. A table identifying all the LED states and their diagnostic error codes appears in **Appendix A** on page 16. Failures identified by the diagnostics incorporated in the SC-200 can be classified either as errors in setting up the module during installation that should be corrected before the SC-200 module is brought online, or operational failures that occur sometime after the module has been properly installed and put into service. There can be different error code outputs for each of these two types of failures, as shown in **Appendix A** on page 16.

If an error code or failure is presented, it usually requires a "soft" reset to clear it, but occasionally might require powering the module down and back up ("hard" reset) to clear it. To initiate a soft reset on an SC-200, depress the **FULL SCALE** button three times in a row for at least half a second each time, or enter the **Reset** command for that particular module's digital address over the RS-485 bus.

Failure Warning Output Signals

Any operational failures shown in Table 6 will activate a failure warning output signal to an open-collector transistor switch to (+) power rated at 50 mA to operate a relay, alarm, or pull-up resistor for TTL output pulse. This switch's factory default is normally closed (NC), but can be changed to normally open (NO) by the **Set FOP** RS-485 command. This failure warning signal has a short, programmable delay (default: 200 ms) before activation to eliminate trips due to noise spikes, nearby lightning strikes, and similar transients.

While set up errors shown in Table 6 are being corrected, the failure warning outputs can be deactivated using the **Errsig** RS-485 command toggled to OFF, or by holding down the FS button and then pressing the Z button two times in a row for at least half a second each. However, the failure LEDs will still be operating. When all setup errors have been corrected, a calibration can be done and the failure outputs should be reactivated using the **Errsig** command toggled to ON, or by repeating the procedure with the pushbuttons.

In order for an SC-200 module to work with an LVDT or a half-bridge with low secondary DC resistance, its secondary short diagnostic is disabled by default. To enable this function, hold down the FS button and press the Z button three times in a row for a half-second each time to toggle it ON, or use the command **Errsec ON** over the RS-485 bus. If a secondary short were to develop, LEDs **E** steady on and **S** blinking will be displayed, along with error code 1024 appearing on the RS-485 bus.

Troubleshooting LVDT Connections

Table 6 shows that the SC-200's front panel LEDs indicate most common LVDT wiring failures. If a front panel LED indicates an open winding, turn off the DC power and troubleshoot the LVDT wiring with an ohmmeter. Double check the LVDT's lead wire colors or connector pins against the specifications for that LVDT to be sure that all of the wires are correctly identified and properly connected.

When running cables between LVDTs and signal conditioners, a common wiring error is failure to properly connect the two secondaries together, separate from the other connections. For the SC-200, the secondaries of the LVDT are connected together in a series-opposing configuration, so the module can operate on the net differential AC output that results from this winding connection. It is strongly recommended that the interconnection of the secondaries be done at the LVDT itself, before any cabling or wiring is attached, especially with a long cable run between the LVDT and the module. Normally the junction of the two secondaries is not connected to the signal conditioner, but if an SC-200 is to be hooked up in close proximity to a leaded LVDT, and if J2-1 is not being used for a shield ground point by jumpering J9, the secondary interconnection may be hooked up to J2-1 as a convenient tie point that is not connected to the module.

Grounding and Shielding

The most common problem encountered with grounding and shielding of a sensor circuit is current flow in the ground circuit, called a ground loop. To avoid ground loops, a circuit must have only one common ground point. An SC-200 module's terminals J3-3 and J4-3 share the same common ground, so, to avoid ground loops, a single wire should be run to the system ground from just one of these ground terminals. Best practice is not to connect any sensor cable shield to the LVDT sensor's housing or to any separate or intermediate system ground point. Connect any sensor cable shields as simple Faraday shields only to the SC-200's ground points at J3-3 or J4-3. If more convenient cable shield ground points are needed for an SC-200 operating from unipolar DC voltage (not ± 15 V DC), put the 2-pole shunt jumpers supplied onto J8 and J9 (located next to J2), which will convert J2-3 and J2-1 into additional ground points for cable shields.

Commands for the RS-485 port

Commands for transmission over the SC-200's RS-485 communications link can be sent from a PC using an ASCII terminal program like Hyper Terminal and a 2-wire RS-485 adapter from an RS-232 or USB port. The port adapter must be connected with the proper data polarity: (*D+*) to J3-1 and (*D-*) to J3-2. The port communication parameters are: 9600 bps, no parity, 8 data bits, 1 stop bit (9600, NP, 8, 1) with echo on and no flow control. Note that all commands must be preceded by a module address in the specific format: **Uxx(space)**, where **xx** is the numerical value, 00 to 15, of the module's decimal digital address as set with DS2 using **Appendix C** or by referencing the DIP switch settings shown on the left side label of the module.

Note: Some **Set** command descriptions show in bold face the range of values that follow the command and (*space*).

Analog In *RUN* mode, returns the nominal analog output value scaled in electrical units that depend on the setting of DS1, or the analog output range selected with the **Set Aout** command.

Cal Enters *CALIBRATION* mode; command is the same as pressing **FULL SCALE** and **ZERO** pushbuttons together.

Clrall In *RUN* mode, clears EEPROM of all RS-485 command settings used to override module DIP switch settings.

Config Lists the module's setup data and displays DIP switch settings and current EEPROM values. Specifically, it shows the module's firmware version, operating mode, digital address (*00 - 15*), date stamp, serial number, analog output setting (*1 - 8*), excitation frequency setting (*0 - 3*), output invert switch *off* or *on*, low frequency filter status (LF) *off* or *on* and filter corner frequency, excitation drive jumper (J7) *in* or *out*, failure output delay time (FD) and polarity (FOP) *NC* or *NO*, Lock status, and stored EEPROM values for ADC Lo, ADC Hi, Input pot, and Gain pot. (Log and store all **Config** data and values by digital address to be able to reconfigure a hot swapped module at a later time).

Error In *RUN* mode, displays any setup or operations error code(s); for multiple errors, error code sum is displayed.

Errsec In *RUN* mode, **ON**, **OFF** (*default*) toggles error indications and failure outputs from low DCR secondaries.

Errsig In *RUN* mode, **ON** (*default*), **OFF** toggles error indications and failure outputs for all errors found during setup.

Exit Required to exit *CAL* mode, or to exit any **Set** command writing a value to the module's EEPROM in *RUN* mode.

FS In *CAL* mode, sets the module's full scale output point at the LVDT core's maximum position and is the same as pressing **FULL SCALE** pushbutton. Occasionally it may require setting a second time after using the **Z** command.

Help Shows all user commands available for execution over the RS-485 bus, including a few not shown in this list.

LEDs In *RUN* and *CAL* modes, outputs the status of the 3 green LEDs, displayed in **S-E-P** order, e.g.: - * **0** means **S** LED is off, **E** LED is flashing slow, and **P** LED is on. + is a fast flash and ! indicates alternating solid and flashing.

Lock In *RUN* mode, locks the module against any changes and displays attempted tampering over the RS-485 bus.

Null In *RUN* mode, displays the Null Output voltage at any core position and is typically used to verify that the core of an LVDT is at null; may also be used to establish the symmetry of an LVDT's endpoint outputs versus core position.

Read LF In *RUN* mode, when DS2-4 is *ON*, or the LF filter is invoked, shows the status and frequency setting of the supplemental low pass filter.

Recal FS In *RUN* mode, after a calibration has been completed, if the actual full scale output value is within $\pm 4\%$ of the nominal full scale output value selected by DS-1 or the **Set Aout** command, this command trims the actual full scale output value to match the selected full scale output value. The command may be repeated once to get the most precise FS output value. Recal can be set at module by pressing **FULL SCALE** button until the **POWER** LED blinks.

Recal Z In *RUN* mode, after a calibration has been completed, if the actual zero output value is within $\pm 5\%$ of the nominal zero output value selected by DS-1 or the **Set Aout** command, this command trims the actual zero output value to match the selected zero output value. This command may be repeated once to get the most precise zero output value. Recal can also be set at the module by pressing the **ZERO** pushbutton until the **POWER** LED blinks.

Reset In *RUN* mode, produces a "soft" reset of the module's processor so the module restarts as if it is powering on. Command is the same as pressing the **FULL SCALE** pushbutton three times for at least one-half of a second each.

Reset All In *RUN* mode, using prefix **U90** instead of **Uxx**, this command performs a simultaneous "soft" reset on all modules connected to the RS-485 bus. Each module on the RS-485 bus then restarts itself as if it is powering on.

Restore In *RUN* mode, resets module to factory set condition by cancelling all user setup values stored in EEPROM. It can also be invoked by pressing the **ZERO** pushbutton three times in a row for one-half of a second each time.

Set ADC Hi In *RUN* mode, writes an A/D converter high value into module's EEPROM. Command is used during a hot swap module reconfiguration to enter the ADC Hi value logged from the original module's **Config** command.

Set ADC Lo In *RUN* mode, writes an A/D converter low value into module's EEPROM. Command is used during a hot swap module reconfiguration to enter the ADC Lo value logged from the original module's **Config** command.

Set Aout In *RUN* mode, permits setting the analog output range: **1 - 8**, independent of the setting of DIP switch DS1.

Set Exf In *RUN* mode, permits setting excitation frequency: **0 - 3**, independent of settings of DIP switches DS2-1, -2.

Set FD In *RUN* mode, permits the user to set the delay time before the failure warning output switch is activated from 0 to 900 msec in 100 msec increments: **0 - 9**. The factory default delay time is set at 200 msec.

Set FOP In *RUN* mode, sets failure warning switch polarity: **NC**, Normally Closed (*default*) or **NO**, Normally Open.

Set Gain In *RUN* mode, writes a Gain pot value into module's EEPROM. Command is used during a hot swap module reconfiguration to enter the Gain pot value logged from the original module's **Config** command.

Set In Pot In *RUN* mode, writes an Input Pot value into module's EEPROM. Command is used during a hot swap module reconfiguration to enter the Input Pot value logged from the original module's **Config** command.

Set Inv In *RUN* mode, permits inverting analog output by overriding setting, **ON**, **OFF**, of invert DIP switch DS2-3.

Set LF In *RUN* mode, sets the corner frequency of the supplemental low pass filter between 0.1 Hz and 10 Hz. If DS2-4 is not *ON*, command permits LF filter status to be changed: **ON**, **OFF**, and its corner frequency to be set.

Ver In *RUN* mode, returns the version number of the module's firmware.

Z In *CAL* mode, sets the module's zero output point at the minimum position of the LVDT's core; function is the same as pressing the **ZERO** pushbutton. Occasionally it may require setting a second time after using the **FS** command.

Endpoint Recalibration Process

In certain circumstances, it may be desirable to perform a "hot" recalibration on a module, typically from the effects of thermal expansion and/or contraction on a mechanical system. Recalibration permits trimming of either end point's analog output in a system that is already calibrated, provided that the actual output values from the module are within $\pm 5\%$ of the full span of the output chosen by the setting of DS-1 or the **Set Aout** RS-485 command. Recalibration can be used to trim either end point's analog output independent of the other and is done while the module is operational, so it has an immediate effect upon the system's analog output. Recalibration can be done with one of two RS-485 commands, **Recal FS** and **Recal Z**, or by depressing the **FULL SCALE** or **ZERO** buttons until the **POWER** LED flashes once.

Before proceeding to perform a recalibration, verify that the difference between the actual output value at the end point to be trimmed is within $\pm 5\%$ of the span of the analog output for which the module was set, where the span is the difference between the maximum and minimum values of the selected analog output. Thus, the trimmable range of actual output at the system's Zero point is -5 to 5% of the span, and at the Full Scale point, it is 95 to 105% of the span. If the analog output at an end point is not within the limits noted, the attempt at recalibration will not be effective. Recognize that if the directional sense of the LVDT has been inverted by turning on S1-3, the actions of the **FULL SCALE** or **ZERO** pushbuttons are also inverted.

To perform a recalibration, move the workpiece to the end point to be recalibrated and invoke the **Recal** command for that end point over the RS-485 bus, or depress and hold down the button for that end point until the **POWER** LED flashes once. Repeating the process once is permissible, but not more than once.

Hot Swapping Modules

An SC-200 module connected in a multi-module array can be "hot swapped" with another SC-200 module having the same internal DIP switch and jumper settings, and having values loaded in specific EEPROM locations that match those in the original module. Carefully done, this process can make the replacement module's characteristics match those of the module being taken out of service within approximately 1% and will also allow the remaining modules in the array to continue operating in a normal manner.

To prepare the replacement module for a hot swap, the configuration data of the original module, which should have been obtained previously and saved for a possible hot swap, is needed. If this data is not available, connect to the RS-485 port of the original module with a PC and terminal program, and use the **Config** command to get it. Using that data, set the internal DIP switches and jumpers of the new module to match, then power it up and use its RS-485 port as noted above to load the "standardized" values of ADC Hi, ADC Lo, In Pot, Gain, and any values for FOP, FD, LF, Aout, Exf, and Inv, using their **Set** commands.

To perform a hot swap, first shut down the positive power input connected to J4-4, the red plug, from the original module, which may be done by pulling the power fuse, or tripping the circuit breaker, or switching off the power switch for that module, or by loosening the screw terminal of J4-4 and carefully removing the wire. Do not remove the red plug itself with any power present. Once the unit has been depowered, the plugs may be disconnected from the original module in order of: J4 (red), J3 (green), J2 (blue), then J1 (black). Reverse the sequence to plug back into the replacement module. Finally, reconnect positive power.

Replacing an SC-100 Module with an SC-200 Module

To hot swap an SC-100 with an SC-200, insert a shunt jumper (supplied) onto J201 (near the center of the pcb) to invoke the SC-100 emulation mode of the SC-200 replacement module. In this mode the module will operate in the manner of an SC-100. Follow the instructions above for DIP switch setup and to load the configuration data from the original SC-100. Then follow the de-powering and re-powering instructions. Note that the same terminal connections used with an SC-100 can be utilized with the SC-200 in SC-100 mode, by connecting up to the screw terminal plugs supplied with the SC-200. One additional note: the default failure warning output for an SC-100 is Normally Open, but for an SC-200 it is Normally Closed. If the module's failure output switch polarity needs to be changed, refer to the **Set FOP** RS-485 command.

Although the system can be operated in SC-100 emulation mode indefinitely, the module match may not be ideal, so for optimum performance, when a suitable opportunity presents itself, restore the new module to SC-200 mode by removing the shunt jumper on J201 and the system should be calibrated again.

SC-200 Specifications

Operating power:	+15 to +30 V DC (+24 V DC nominal), 100 mA maximum at 24 V DC; +15 V DC and -15 V DC needed for ± 10 V DC bipolar output
Excitation voltage:	3.0 Vrms (nominal) push-pull drive (factory default) 4.5 Vrms (nominal) push-pull drive (jumper J7 removed) 1.5 Vrms (nominal) single-ended drive for low impedance primary
Excitation frequencies:	2.5 kHz, 5 kHz, 7.5 kHz, 10 kHz (nominal)
Auto-master syncing:	Master output couples up to fifteen slave inputs; if original master fails, new master is automatically generated for fail-safe excitation control.
LVDT AC output range:	50 mVrms to 5000 mVrms at LVDT's full scale position
Analog DC outputs:	0 - 5 V, 1 - 5 V, 0.5 - 4.5 V, 0.5 - 9.5 V, 0 - 10 V, -10 to +10 V, 0 -20 mA 3-wire sourcing, 4 -20 mA 3-wire sourcing
Loop resistance:	850 Ohms maximum with 24 V DC supply
Output non-linearity:	$\leq \pm 0.025\%$ of Full Span Output (FSO)
Frequency response:	Standard -3 dB BW: 10% of excitation frequency (minimum) Low noise -3 dB BW: 0.1 - 10 Hz (default), user settable
Noise and ripple:	≤ 1 mVrms (voltage output), or ≤ 2 μ Arms (current loop output.)
Fault detection:	Open LVDT winding, shorted or grounded LVDT connection; LVDT cable disconnected; open or shorted analog output
Fault indication/output:	Flashing LED's; N.C. 50 mA solid state switch, user settable to N.O.
Null detection:	Front panel LEDs, ± 30 mV threshold out of about ± 1.6 V signal level
Null output signal:	± 3 V DC max. (floating)
Operating temperature:	-20 to 75 C
Temperature Coefficient	$\pm 0.0025\%$ of FSO/ $^{\circ}$ C (combined span and zero shifts)
Zero set:	Front panel push button or RS-485 ASCII command
Full Scale set:	Front panel push button or RS-485 ASCII command
Digital interface:	RS-485 2-wire half-duplex multi-drop network, 16 individual addresses

SC-200 Module Outline Dimensions

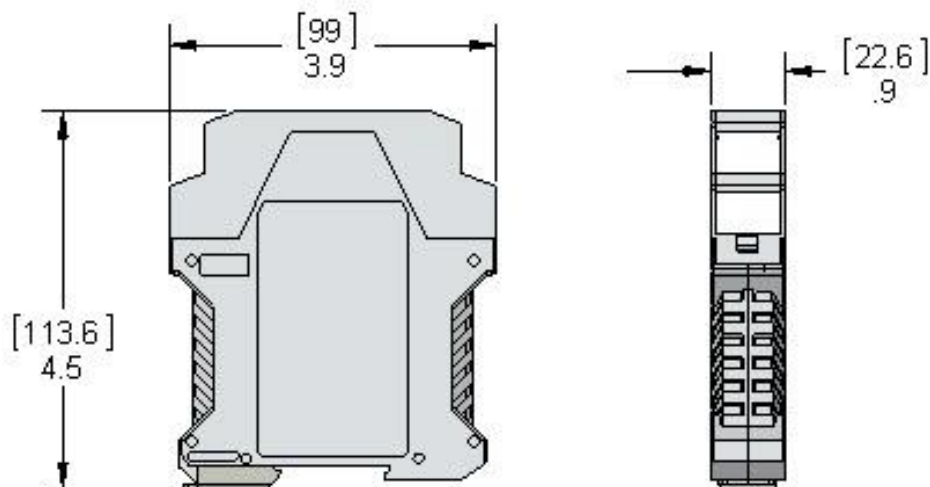

Appendix A: SC-200 Error Codes and Fault Matrix

LED display	Code	Error / Fault	Description / Diagnosis	Setup Errors		Operating Faults	
				Analog Fault Output	Failure Warning Output	Analog Fault Output	Failure Warning Output
P , E , S , and POWER LEDs in <i>RUN</i> Mode	RS-485 Error Code						
P blinking	1	LVDT primary circuit open	Open circuit in LVDT primary or its wiring	yes	yes	yes	yes
P alternates blinking with steady on	1	Open LVDT primary circuit on master module	Open LVDT primary circuit or wiring on master module	yes	yes	yes	yes
S blinking	2	LVDT secondary circuit open	Open circuit in LVDT secondary or its wiring	yes	yes	yes	yes
P and S both blinking	3	LVDT not connected	LVDT not connected	yes	yes	yes	yes
P alternates blinking with steady on and S blinking	3	LVDT not connected to a master module	LVDT not connected to a master module	yes	yes	yes	yes
E blinking	4	LVDT excitation signal drops low	Excitation level drops low due to overload from low LVDT primary impedance	yes	yes	yes	yes
E alternates blinking with steady on	8	No excitation signal to LVDT	No excitation signal detected; possibly a primary short circuit or misconnection	yes	yes	yes	yes
E alternates blinking with steady on	16	Loss of LVDT excitation signal	No excitation signal detected; internal failure of excitation generator	yes	yes	yes	yes
S steady on	32	Excitation frequency error in slave module	Slave DIP switch setting different from master's DIP switch setting	yes	yes	n/a	n/a
E steady on	64	Sync bus for slave modules has short circuit	No sync pulse detected on sync bus pin of slave modules upon startup.	yes	yes	n/a	n/a
E and S both steady on	128	Sync pulse timeout error	Sync start pulse not detected on bus after specified elapsed time	yes	yes	n/a	n/a
E blinking and S steady on	256	External syncing frequency mismatch	External sync frequency outside range of current DIP switch setting	yes	yes	n/a	yes
E steady on and S blinking	1024	Short on LVDT output signal	LVDT secondary shorted across or to ground	yes	yes	yes	yes
E and S both blinking	2048	Analog output connection fault	Loop open in current mode; output short in voltage mode	yes	yes	yes	yes
P and S both blinking and E steady on	4096	LVDT input overload error; calibration error	LVDT output overdriving system; new calibration required	yes	yes	yes	yes
P , E , and S green LEDs all blinking	8192	Alert of attempted tampering with a locked module	Response to a tampering attempt involving a locked module	no	no	no	yes

Note 1: In a master/slave connection, the master module will show **P** steady on along with an error LED display.

Note 2: RS-485 error codes that result from multiple faults are additive; e.g.: error code 128 combined with error code 16 results in an error code 144 response to a **CONFIG** or **ERROR** command sent over the RS-485 bus.

Appendix B: Cybersecurity Features of the SC-200 Module

Because Alliance Sensors Group's model SC-200 LVDT signal conditioner module is a microprocessor-based electronic product, some users are naturally concerned about potential vulnerabilities to any type of cyberattack. For this reason, the SC-200 module has been equipped with significant cybersecurity features. Foremost of these features is the fact that there is no physical or electronic connection to the Internet. There is a RS-485 communications port built into an SC-200 module, but it has no access whatsoever to the operating firmware of the module, so the module cannot be subverted by attempts to access its operating system. Thus, it is protected at the highest level from any malevolent cyberattacks.

However, the RS-485 port does permit certain operational parameters to be adjusted by ASCII commands transmitted over the module's RS-485 bus. To prevent tampering with any of the module parameters that had been set up when the module was installed, the SC-200 module offers a lock feature that prohibits any tampering with the module's setup and can notify a user of any attempt to tamper with the module. This lock feature can be initiated over the RS-485 bus with the appropriate command, or it can be physically set at the module by using the locking process noted below. In either case, the module cannot be unlocked over the RS-485 bus. It can be only unlocked and reset by an authorized person who has been instructed in the specific unlocking process that must be applied to the module itself. Thus, this person must be someone who has already been cleared by security and who is present inside the facility.

This lockout approach to cybersecurity puts the emphasis on the facility security systems and personnel. Most users already have substantial security safeguards in place, so this approach is unlikely to place any extra burden on either the facility's security systems or personnel.

Applying the Lock Code to an SC-200 Signal Conditioning Module

One way the lock feature of an SC-200 can be applied is by invoking the **Lock** command over the unit's RS-485 port, using the syntax shown on page 12. There is no bus-wide ASCII **Lock** command, so each SC-200 module must be locked separately. The other method of applying the lock feature is done at each module itself by depressing and holding down the ZERO pushbutton on the SC-200's front panel and simultaneously depressing the FULL SCALE pushbutton three times in a row for at least 0.25 seconds each time. When lock takes effect, the POWER LED will flash once, indicating that the lock has been engaged. When an SC-200 is locked, it will still respond to informational data commands such as **Config, Analog, Ver**, etc., but it will react to transformational commands or actions such as **Recal, Set, Reset, Clrall**, etc., as tampering. If anyone attempts to tamper with a locked module, the front panel green LEDs will flash continuously, the failure warning will go off, and a tamper code (8192) will be output on the RS-485 bus. It is important to note that the correction of any errors exhibited by the module require the lock to be removed.

Applying the Unlock Process to a Locked SC-200 Signal Conditioning Module

As noted above, an SC-200 module that has been locked can only be unlocked by someone applying the unlocking process directly to the locked module. There is no RS-485 command for the unlocking process. Furthermore, any attempt to unlock the module without going through the unlocking process will trigger a tampering alert. The unlocking process is the same as the locking process applied at the module itself by depressing and holding down the ZERO pushbutton on the front panel and simultaneously depressing the FULL SCALE pushbutton three times in a row for at least 0.25 seconds each time. On the second push of the FULL SCALE button, any tampering alert will be discontinued. On the third push, the unlocking action will take effect and the POWER LED will flash once, indicating that the module's lock has been released.

Appendix C: DIP Switch DS-2 Settings Table for Decimal Digital Addresses

Digital Address	00	01	02	03	04	05	06	07	08	09	10	11	12	13	14	15
DIP switch DS2-5	OFF	OFF	OFF	OFF	OFF	OFF	OFF	OFF	ON	ON	ON	ON	ON	ON	ON	ON
DIP switch DS2-6	OFF	OFF	OFF	OFF	ON	ON	ON	ON	OFF	OFF	OFF	OFF	ON	ON	ON	ON
DIP switch DS2-7	OFF	OFF	ON	ON	OFF	OFF	ON	ON	OFF	OFF	ON	ON	OFF	OFF	ON	ON
DIP switch DS2-8	OFF	ON	OFF	ON	OFF	ON	OFF	ON	OFF	ON	OFF	ON	OFF	ON	OFF	ON