

# ALLIANCE SENSORS GROUP

---

A DIVISION OF H.G. SCHAEVITZ LLC

## **S2A** *Signal Conditioner Module for AC-LVDTs, RVDTs, LVRTs, and Half-bridges*

---

### Setup and Operating Instructions

---



**Alliance Sensors Group**  
7300 US Rt.130 North, Bldg. 22  
Pennsauken, NJ 08110 USA  
[www.alliancesensors.com](http://www.alliancesensors.com)

P/N 5700-0014, Rev R8 6-1-2024

## EC/EU Declaration of Conformity

The undersigned, representing **Alliance Sensors Group, a Division of H. G. Schaevitz, LLC, 7300 US Rt.130 North, Bldg. 22, Pennsauken, NJ 08110 USA,**

hereby declares that the product, **Model S2A LVDT Signal Conditioner Module,**

of the following category and type: **Measurement, Control Equipment, and Laboratory Use,**

is in conformity with the provisions of the following EC/EU directives: **EMC Directive 2014/30/EU; RoHS 2 Directive 2011/65/EU**

Testing was done to requirements as stated in harmonized standards **EN 61326-1: 2013 and CISPR 11: 2009, A-1: 2010, Group 1, CI A**

using the methods noted hereafter: **IEC 61000-4-2: 2008, IEC 61000-4-3: 2006, A-1: 2007, A-2 2010, IEC 61000-4-8: 2009**

A TCF for the product is maintained for inspection at the location noted.

Edward E. Herceg

Edward E. Herceg, VP, CTO

Oct 1, 2018

Date of Issue

---

## Product Warranty

Alliance Sensors Group warrants the Model S2A LVDT Signal Conditioner to be free from defects in workmanship and materials for a period of two (2) years from the date of shipment. In the event a valid claim is made under this warranty, the only obligation of Alliance Sensors Group is to repair or replace the unit. ***Under no circumstances will Alliance Sensors Group be liable for fitness of purpose by the user or any damages, direct, consequential, or otherwise, or for any damage to any sensor connected to the S2A LVDT Signal Conditioner, or for any damage to any electronic equipment connected to the inputs or outputs of the S2A LVDT Signal Conditioner.***

To submit a claim under the provisions of this warranty, the claimant must secure an RMA (Returned Material Authorization) number by contacting Alliance Sensors Group at: 856-727-0250, or by sending a letter, or by e-mailing [sales@alliancesensors.com](mailto:sales@alliancesensors.com). The defective unit must be returned freight prepaid to Alliance Sensors Group for inspection, accompanied by the RMA number and a letter of explanation of the purported defect. If the factory inspection and evaluation validates the warranty claim, the repaired or a replacement unit will be promptly returned to the claimant freight prepaid.

If inspection and evaluation of the device determines that it has been misused, abused, misapplied, or modified by the user; has been subjected to a fire, flood, or mishandling; or is damaged due to improper packing for the return shipment, no warranty claim will be allowed or accepted. Instead, the unit will be returned to the claimant freight collect, along with an invoice for the evaluation charge.

Any questions about Alliance Sensors Group's warranty provisions can be answered by contacting Alliance Sensors Group at: 856-727-0250, or by sending an e-mail query to: [sales@alliancesensors.com](mailto:sales@alliancesensors.com).

# PREFACE

In this manual, you will find a chart on page 4 for quickly connecting your AC-LVDT, AC-RVDT, LVRT, or inductive half-bridge sensor to this model S2A DIN-rail mounting, 24 Volt DC-operated signal conditioning module, and a **Quick Start Guide** on page 5 for calibrating it with the two front-panel push buttons, which eliminate any need for external pot adjustments. The internal DSP (Digital Signal Processor) will lead you through the various calibration steps by means of the three green LEDs on the module's front panel, as illustrated on page 2. The term *LVDT* is used generically throughout these instructions for any low voltage audio frequency AC-operated position sensors, i.e. LVDTs, RVDTs, LVRTs, and inductive half-bridges.

You will also find the S2A specifications and a detailed description of the advanced functions available for applications where you may wish to go beyond the basic features. Such possibilities include the master / slave synchronization of the excitation for multiple LVDTs, an open-collector failure warning switch output, the DC voltage null position indicator signal, and digital communications via the RS-485 addressable multi-drop port. The S2A also incorporates a settings locking feature for enhanced cybersecurity by preventing and displaying any attempts at tampering with the module. The S2A LVDT Signal Conditioner module is CE compliant for both EMI and RoHS. To assure long, maintenance-free life, all inputs and outputs are ESD protected, along with protection against reverse voltage, overvoltage, and short circuits. Operating current and power-on inrush current are also limited by solid-state resettable fuses.

## TABLE of CONTENTS

<b>Identification of Front Panel LEDs and Switch Functions</b>	<b>2</b>
<b>Identification of DIP Switches and I/O connections</b>	<b>3</b>
<b>LVDT Wiring Configurations</b>	<b>4</b>
<b>Quick Start Guide</b>	<b>5</b>
<b>Functional Description of the S2A</b>	<b>6</b>
<b>DC Power Input`</b>	<b>6</b>
<b>LVDT Primary Excitation</b>	<b>6</b>
<b>Inductive Half-Bridge Connections</b>	<b>6</b>
<b>Master/Slave Synchronization</b>	<b>6</b>
<b>LVDT Output Signal</b>	<b>7</b>
<b>DC Output Filtering</b>	<b>7</b>
<b>Failure and Fault Indicators</b>	<b>7</b>
<b>RS-485 Communications</b>	<b>7</b>
<b>Expanded Calibration Procedure</b>	<b>8</b>
<b>Terminology and Definitions</b>	<b>8</b>
<b>Calibration Procedure</b>	<b>8</b>
<b>Null Point Location</b>	<b>8</b>
<b>Null Indicator Output</b>	<b>9</b>
<b>Setting Full Scale Output Point</b>	<b>9</b>
<b>Setting Zero Output Point</b>	<b>9</b>
<b>Alternative Calibration Procedure</b>	<b>10</b>
<b>Live Zero and Extra-range Outputs</b>	<b>10</b>
<b>Using the Voltage and Current Outputs</b>	<b>10</b>
<b>Failure Diagnostics</b>	<b>11</b>
<b>Failure Warning Output Signals</b>	<b>11</b>
<b>Troubleshooting LVDT Connections</b>	<b>12</b>
<b>Grounding and Shielding</b>	<b>12</b>
<b>Commands for the RS-485 Port</b>	<b>12</b>
<b>End point Recalibration</b>	<b>14</b>
<b>Hot Swapping Modules</b>	<b>14</b>
<b>Replacing an S1A Module with an S2A Module</b>	<b>14</b>
<b>Specifications and Module Dimensions</b>	<b>15</b>
<b>Appendix A: Error Codes and Fault Matrix</b>	<b>16</b>
<b>Appendix B: Cybersecurity Features of the S2A Module</b>	<b>17</b>
<b>Appendix C: DIP Switch Settings Table for Decimal Digital Addresses</b>	<b>17</b>

# Front Panel LEDs and Switches (Use with **Quick Start Guide** on page 5)

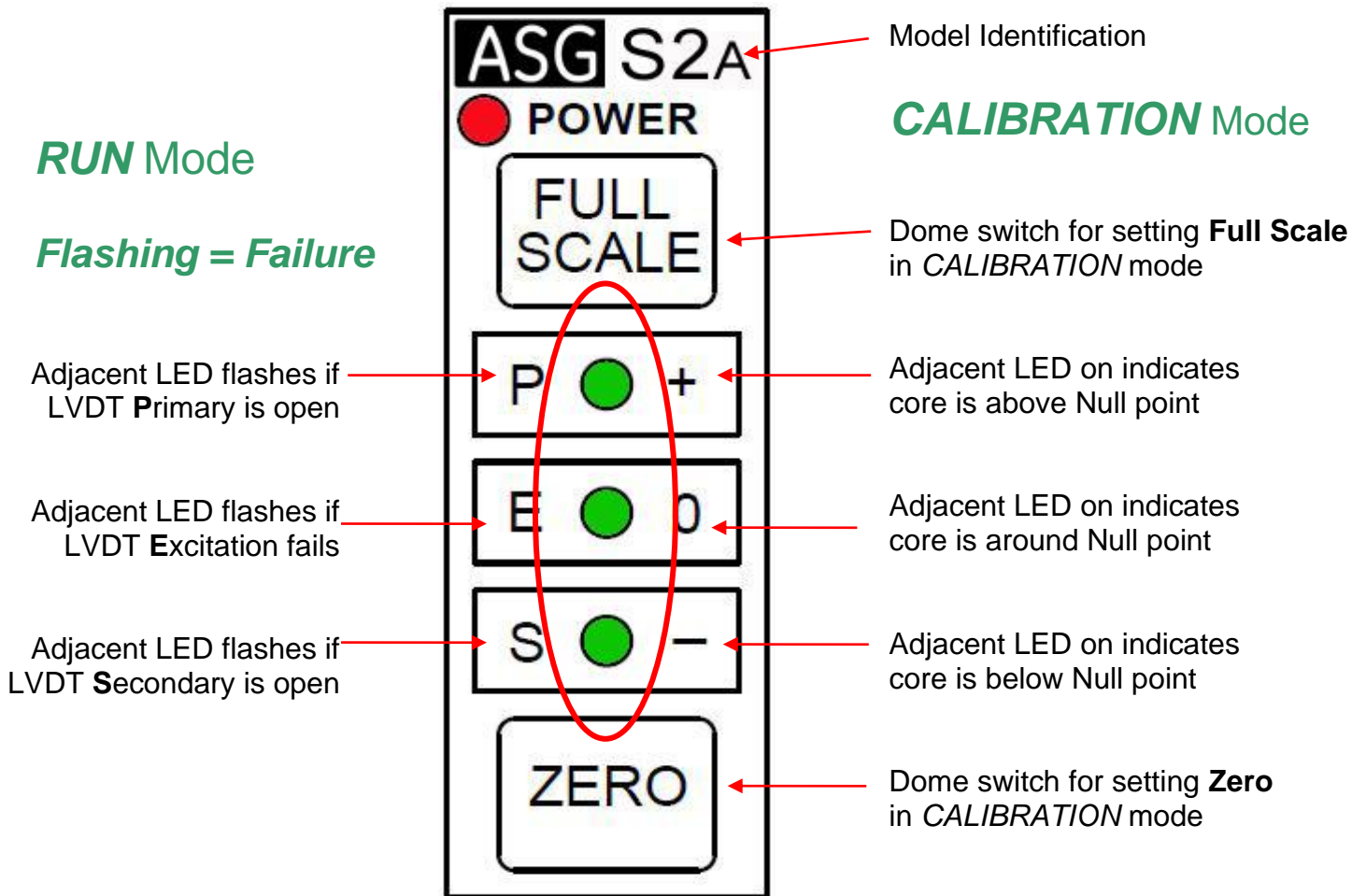

**Figure 1** S2A front panel with calibration pushbuttons and LEDs to show LVDT Null Point and failures

# DIP switch functions & I/O connections (Use with Quick Start Guide on page 5)

<b>Excitation Frequency</b>	1 kHz	<b>3 kHz</b>	5 kHz	10 kHz	<b>DIP Switch State</b>	<b>OFF</b>	ON
DIP switch <b>DS2-1</b>	OFF	<b>ON</b>	OFF	ON	DIP switch <b>DS2-3</b>	<b>Normal Output</b>	Inverted Output
DIP switch <b>DS2-2</b>	OFF	<b>OFF</b>	ON	ON	DIP switch <b>DS2-4</b>	<b>No LF Filtering</b>	LF LP Filter ON

**Table 1** DS-2 Excitation Frequency Settings.

**Table 1a** DS2 Analog Output Modifier Settings.

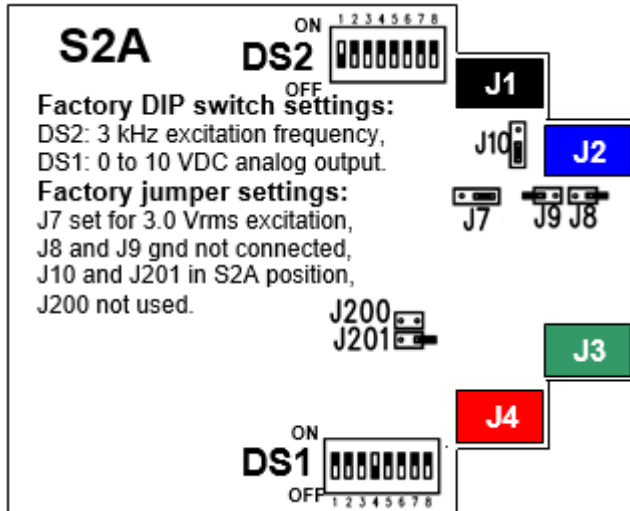

**Figure 2** S2A DIP Switch and Jumper Locations

<b>DIP Switch DS2-No.</b>	<b>5</b>	<b>6</b>	<b>7</b>	<b>8</b>
DIP Switch ON to Add	8	4	2	1

**Table 1b** Digital Address Setting Schema; DS2 Switches **5, 6, 7, 8**: Factory Set **OFF**. A Table of DIP Switch Settings for Decimal Digital Addresses is in **Appendix C**, Pg. 17

All factory DIP switch settings are in **bold**.

DS-1 and DS-2 DIP switch settings are also shown on the left side label of module case.

<b>DS1 Switches</b>	1	2	3	4	5	6	7	8
<b>Output with DS1-No. ON</b>	0 to 5 Volts	1 to 5 Volts	0.5 to 4.5 Volts	<b>0 to 10 Volts</b>	-10 to +10 Volts	0.5 to 9.5 Volts	0 to 20 mA	4 to 20 mA

**Table 2** DS1 Analog Output Settings; only one switch is allowed to be set ON, all others must be set OFF.

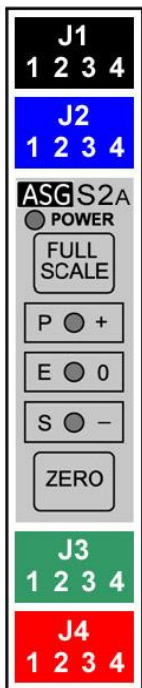

**Figure 3** Front View

<b>J1-1</b>	<b>Black</b>	LVDT Primary High <b>or</b> Half-bridge High End
<b>J1-2</b>	<b>Black</b>	LVDT Primary Low <b>or</b> Half-bridge Low End
<b>J1-3</b>	<b>Black</b>	LVDT Secondary Low (Ground if J10 is set in half-bridge mode)
<b>J1-4</b>	<b>Black</b>	LVDT Secondary High <b>or</b> Half-bridge Mid-tap
<b>J2-1</b>	<b>Blue</b>	LVDT Secondaries Junction Point (Shield Ground if J9 is ON)
<b>J2-2</b>	<b>Blue</b>	Failure Warning Output (Open Collector Switch, 50 mA max.)
<b>J2-3</b>	<b>Blue</b>	-15 V DC input for ±10 V DC output (Shield Ground if J8 is ON)
<b>J2-4</b>	<b>Blue</b>	Sync Input / Output (Master / Slave Bus)
<b>J3-1</b>	<b>Green</b>	RS-485 Data Line (D +)
<b>J3-2</b>	<b>Green</b>	RS-485 Data Line (D -)
<b>J3-3</b>	<b>Green</b>	Analog Output Ground ( <b>Common Ground</b> )
<b>J3-4</b>	<b>Green</b>	Analog Output (+) (Voltage or Current, as selected with DS1)
<b>J4-1</b>	<b>Red</b>	Null Indicator Differential DC Output (floating)
<b>J4-2</b>	<b>Red</b>	Null Indicator Differential DC Output (floating)
<b>J4-3</b>	<b>Red</b>	Power Ground ( <b>Common Ground</b> )
<b>J4-4</b>	<b>Red</b>	Power Input (+) (15 to 30 V DC)

**Table 3** S2A LVDT Signal Conditioner Module Input/Output Connections  
**NOTE: J3-3 and J4-3 share the same Common Ground; use only one ground connection to prevent potential ground loops**

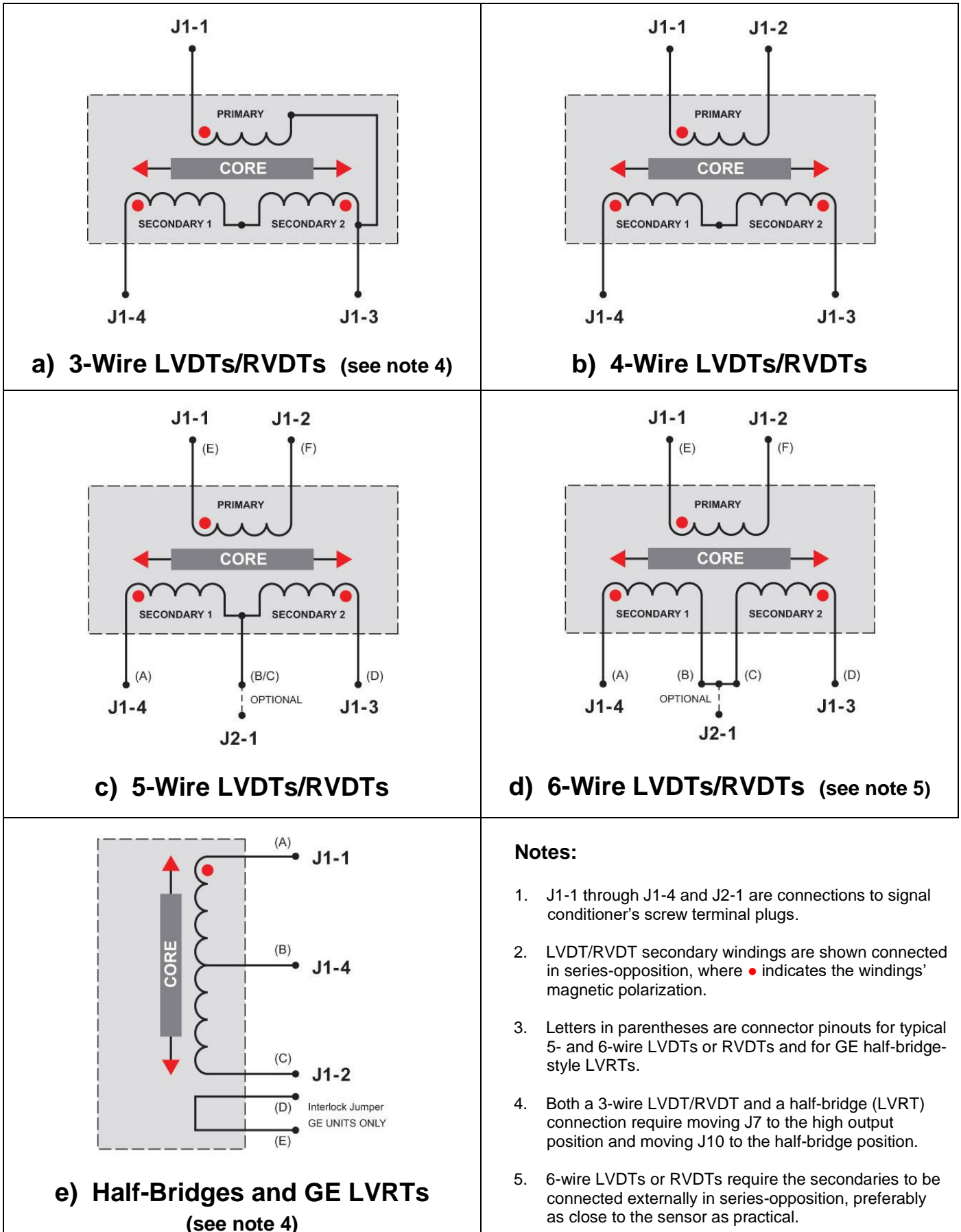

**Figure 4** LVDT or RVDT and Half-Bridge (LVRT) Wiring Connections to S2A Signal Conditioner

# Quick Start Guide for S2A LVDT Signal Conditioner

**1. Default settings:** The S2A factory default LVDT excitation frequency is 3 kHz, which works for most LVDTs, and the default DC output is 0 to 10 Volts. If you can utilize the default settings for excitation frequency and DC output, skip to Step 3. Otherwise, open the S2A module's case by pushing the locking tab inward on both of the thin sides and sliding the case rearward to expose the two circuit-board-mounted DIP switches, DS1 and DS2.

**2. Set the pcb-mounted DIP switches:** LVDT excitation frequency can be changed by setting DS2-1 and DS2-2 according to the left side label or Table 1 on page 3. The DC output can be changed by setting DS1 on the pc board according to the left side label or Table 2 on page 3. When all DIP switch changes are finished, slide the pc board back into the module's case on its internal tracks and snap the two sections of the case back together.

**3. Mount the module:** Remove the color-coded plugs from the S2A module and install the module on the DIN rail by hooking the bottom of the module's rear edge under the bottom edge of the rail, and then pressing the module back against the rail until the spring-loaded rail catch engages the top edge of the rail. To remove the module from the DIN rail, insert a flat-bladed screwdriver into the slot in the metal catch at the top rear of the module, lift the catch upward, and disengage the module from the rail.

**4. Make the I/O connections:** Following the connections on the right side label or in Table 3 on page 3 and the schematics of Figure 4 on page 4, connect the color-coded screw-terminal plugs at least to the LVDT's primary and secondaries (and the secondaries' junction point if needed), to DC power, and to the input of the PLC, control system, or analog output indicator. Never ground J1-1 or J1-2 (black plug) because that will short out part of the excitation voltage. Connections to a failure alarm or the master/slave bus can also be made at this time. When finished, insert the colored plugs completely back into their corresponding colored jacks on the module.

**5. Calibrate the LVDT's core positions:** Turn on the DC power and allow the module to warm up for at least 15 minutes before beginning the calibration procedure. The red **POWER** LED should glow steadily and the green LEDs should be off, except the **P** LED will be steady on if the module is a master (*refer to page 6*) or is operating stand-alone. If any of the other green LEDs are on or flashing, see Appendix A and check all the connections. Calibration cannot proceed if there is an error being displayed. With power applied, the red **POWER** LED on, and no errors being displayed by the green LEDs, LVDT calibration can proceed. **Note:** *The LVDT's core must not protrude from the LVDT at any point during the calibration process or an erroneous calibration will result.*

▶ Shift the module into *CALIBRATION* mode by simultaneously depressing both the **FULL SCALE** and **ZERO** buttons for 3 seconds until the red **POWER** LED begins flashing. The module is now in *CALIBRATION* mode

▶ One of the green LEDs will be illuminated, indicating that the LVDT's core is on one side or the other of null, or at null. As the LVDT's core is moved inward, that LED will go out and the middle LED will come on (showing the LVDT is at null), then the middle LED will go out and the LED on the opposite end (compared to the first green LED that was on) will come on. Adjust the LVDT core's position until the middle green LED is on. The LVDT's core is now approximately at its null or mid-range position.

▶ Move the workpiece whose position is being measured so that it is located at the middle of its range of motion when the LVDT's core is at its null position. Mechanically couple the LVDT core to the workpiece in this position. Now, move the workpiece to the desired Full Scale (end of travel) position and depress the **FULL SCALE** pushbutton until the green **(+)** LED flashes once and the **(-)** LED lights up.

▶ Next, move the workpiece coupled to the LVDT's core to the Zero (start of travel) position at the other end of its range of motion and depress the **ZERO** pushbutton until the green **(-)** LED flashes once.

▶ If one (or both) of the green LEDs is still flashing, rerun the calibration procedure by moving the workpiece and the coupled core to the end position indicated by the flashing LED and depressing its nearby button. The red LED should be flashing, showing that the module is still in *CALIBRATION* mode. To return to *RUN* mode, depress both the **FULL SCALE** and the **ZERO** buttons simultaneously for about 3 seconds until the green LEDs go out and the red **POWER** LED turns on steady. Verify that the analog output and its directional sense (slope) is that which is desired. If the analog output slope is reversed, interchange primary connections or switch DS2-3 *on*.

## Functional Description of the S2A LVDT Signal Conditioner

The S2A is an intelligent LVDT Signal Conditioner module which uses a DSP to sequence and control the various functions of the module. The following descriptions can help a user set up and apply this module.

### DC Power Input

The input power range of +15 to +30 V DC covers the common +24 V DC industrial power supply and the older  $\pm 15$  V DC. For a  $\pm 10$  Volt output, +15 V DC is input to J4-4, -15 V DC is connected to J2-3, and ground to J4-3. If the input voltage rises above 32 V, a Zener diode conducts and a PTC resettable fuse will open if the current becomes too high. After cooling, the fuse will reclose to allow normal functioning to resume. The S2A module avoids a high inrush current with an NTC current limiting device in series with the power circuitry. The module's input is also protected against reverse polarity connection and ESD.

### LVDT Primary Excitation

The AC-LVDT's primary is excited by a digitally synthesized low distortion sine wave signal. The nominal excitation frequency selections are 1, 3, 5, or 10 kHz. The sine wave synthesizer operates from a crystal oscillator, so the resulting frequencies will be very stable. 3 kHz is chosen as the factory default setting, since most commercial LVDTs specify 2500 to 3300 Hz excitation and will operate very satisfactorily at this frequency. To select another excitation frequency, it is necessary to open the S2A module's case and change the settings of DIP switches DS2-1 and DS2-2 according to the left side label or Table 1 on page 3. The excitation frequency can also be selected by **Set Exf** command over the RS-485 bus. (See page 12)

The excitation sine wave has very stable amplitude. The excitation driver operates in push-pull mode to provide about 3 Volts ACrms to the LVDT's primary, but for specific cases, the drive voltage can be raised by 50% by removing internal jumper J7, or decreased by 50% by exciting the primary single ended to ground (using J1-1 and J2-1 with a jumper on J9). A fault detector in the S2A's LVDT excitation circuitry detects if the LVDT's primary is open, shorted, or disconnected. If so, the green **P** or **E** LED on the front panel flashes, a failure warning output is triggered at J2-2, and an error code shows on the RS-485 bus.

### Inductive Half-Bridge Connections

An AC inductive half-bridge sensor, or LVRT, is very similar to an LVDT, but combines an LVDT's primary winding with a center-tapped secondary winding. AC excitation is applied to the ends of the winding and the output signal is taken from the mid-tap. Before hooking up a half-bridge sensor or LVRT to the S2A, move internal jumper J10 from its default position over to half-bridge position, and set J7 for high output. Connect the high end of the half-bridge winding to terminal J1-1, the low end of the winding to terminal J1-2, and the mid-tap to terminal J1-4. See Figure 4e on page 4. The module will now operate the same as it does for an LVDT and will offer the same fault indications as are displayed for a failure of the windings of an LVDT.

### Master/Slave Synchronization

When multiple LVDTs and their interconnecting wiring operate in close proximity, beat frequencies or heterodyning could occur if slight differences exist in the excitation frequencies of the modules. If a beat frequency develops, it will be observed as very low frequency amplitude modulation of the modules' DC output. The best way to avoid such interaction is to synchronize each module's excitation to exactly the same frequency so that beating cannot occur. Typically, one module is chosen as master and the other modules are slaves connected synchronously to the master, using the built-in auto-master sync system.

The S2A modules' auto-master syncing can be implemented as follows: First, all modules must have their excitation DIP switches DS2-1 and DS2-2 set for the same nominal excitation frequency. Second, each module must have a different unit address, which can be set from 00 through 15 by DIP switches DS2-5, DS2-6, DS2-7, and DS2-8 in accordance with the left side label or **Appendix C**. No duplicate addresses are allowed. The factory default address, 00, is usually applied to the master module. Finally, module terminal J2-4 of the master module is connected to terminal J2-4 of up to fifteen slave modules. All the sync connections are protected against ESD or erroneous connections. If the master oscillator were to fail, a new master would be automatically developed to control the excitation oscillator frequency, providing true fail/safe operation. If all of the modules are not powered up at the same time, the module with the lowest numerical address at initial power up will become the master, as indicated by its **P** LED being steady on.



## LVDT Output Signal

The two secondaries of the LVDT are connected together in series-opposing to develop a differential signal. This LVDT output circuit also has a built-in fault detector to warn if the secondaries are open-circuited, not connected together, shorted to ground, or the cable is disconnected. Any fault or wiring failure in the secondaries flashes the green **S** LED on the module's front panel, triggers a failure warning output at J2-2, and shows an error code on the RS-485 bus.

The differential signal from the LVDT's secondaries is demodulated, buffered, and then sent to a 12-bit analog-to-digital converter (A/D) built into the DSP. The amplitude of full scale LVDT output signals accepted extends from 50 mVrms to 5 Vrms, a 40 dB dynamic range. The DSP scales the digital data as needed for the output type that is selected. The digital data are converted back to an analog signal by a digital-to-analog converter (DAC). This analog signal is passed to a buffer/driver stage from which the signal is then delivered as one of the eight user-selectable analog DC outputs: 0 to 5 V, 1 to 5 V, 0.5 to 4.5 V, 0.5 to 9.5 V, 0 to 10 V, -10 to +10 V, 0 to 20 mA, and 4 to 20 mA. The output is chosen by setting one position of 8-section DIP switch DS-1 inside the module to *on* using Table 2, or by the **Set Aout** RS-485 command. (See page 12). The factory default analog output is 0 to 10 V DC (DS1-4 *on*). All unipolar analog outputs feature a "live zero", whereby the output can go below zero so that a user can establish a true zero point.

Besides selecting the specific analog output signal desired, a user can invert the output signal by setting DIP switch DS2-3 to *on*, effectively reversing the slope of the output signal. For example, inverting the 4-to-20 mA output changes it to 20-to-4 mA over exactly the same range of motion for the LVDT's core.

## DC Output Filtering

Within the DSP, the digitized demodulated LVDT signal goes through some digital filtering before being input to the DAC. The DAC's analog output is first sent to a two-pole low pass R/C filter having a -3 dB cutoff frequency of at least 10% of the excitation frequency set by DS2-1 and DS2-2, and then on to the output terminals. For applications requiring very low noise and ripple, the analog output can further filtered by turning DIP switch DS2-4 *ON*, engaging an additional single-pole low pass filter with a -3 dB cutoff frequency that can be programmed between 0.1 to 10 Hz (default) by using the **Set LF** RS-485 command.

## Failure and Fault Indicators

The green front panel LEDs will flash to indicate failures in the cases of an open LVDT primary (**P**), an open LVDT secondary (**S**), or a loss of excitation (**E**). The DSP determines a loss-of-excitation condition exists if anything causes the digital signal to the sine wave synthesizer to be lost. Any of these faults will trigger the failure warning output, an open collector transistor switch that pulls the failure warning output terminal J2-2 either low or high (NO or NC) for any case where the DSP detects a fault or failure. The failure warning output terminal includes protections against overcurrent, overvoltage, and ESD. Page 11 and Table 6 offer more detailed explanations of the LED indications and the failure warning outputs.

## RS-485 Communications

The S2A incorporates an RS-485 two-wire multi-drop serial communications interface for up to 16 devices. This port enables half-duplex serial communications to implement specific ASCII commands listed later in this manual by which a module can be setup and calibrated, and system data can be read and stored on a PC. The PC should be running an ASCII terminal program such as Hyper Terminal and using a 2-wire RS-485 converter for a serial or USB port to connect to S2A module terminals J3-1 and J3-2. See page 12 for detailed information about setting up the RS-485 communications link and the ASCII commands available.

In the future, ASG expects to have a Graphic User Interface (GUI) program to communicate with an S2A via the RS-485 multi-drop com link available for download from the ASG website: [www.alliancesensors.com](http://www.alliancesensors.com). The proposed GUI will facilitate setting up, calibrating, and monitoring any S2A on the 2-wire RS-485 multi-drop network from a remote computer or terminal, as well as saving system-specific configuration data in files which could be reloaded into another S2A module during a hot swap. If all the S2A signal conditioners for a particular application (up to 16 modules) were to be connected in an RS-485 multi-drop configuration, such a network could be connected to a wireless RS-485 interface with appropriate third party hardware and software, which would then permit signal conditioner calibration or configuration from a remote location.

# Expanded Version of the S2A Calibration Procedure

## Terminology and Definitions

To provide a clear explanation of the operation of this product, it is necessary to properly define the following words: *program*, *setup*, and *calibration*. To understand this manual and module, the word *program* is used to describe the operating system resident within the DSP, which is factory loaded and is not accessible to the user. The word *setup* is used to describe the settings chosen by the factory or the user for the LVDT's excitation frequency, analog DC output, and other parameters that can be selected either by the internal DIP switches or via commands using the RS-485 communications port. *Setup* should be done in accordance with the **Quick Start Guide** and the DIP switch settings on page 3. Besides the switches for excitation frequency and analog output, there are choices for additional low pass filtering to improve signal-to-noise ratio, inversion of the analog output slope, and up to 16 individual RS-485 digital addresses.

The word *calibration* is used to describe a process or sequence of actions by which the range of motion of the workpiece is matched to the range of motion of the LVDT to produce the desired electrical output from the system. To begin, the LVDT's body is clamped in place. Next, the LVDT's core is moved to find its Null point or mid-range position. The LVDT's null point is the only repeatable unique position of the core; for most LVDTs, there is no definable *full scale* or *zero* position. The workpiece is moved to the middle of its range of motion and then, without changing the core's position, the two are mechanically coupled to each other. The LVDT core and connected workpiece are moved to the Full Scale or maximum travel position so the module's *Full Scale Output* can be set. Finally, the LVDT core and connected workpiece are moved to the Zero or starting point (minimum) position, where the module's *Zero Output* is set. The result of this process is a typical end-point calibration for the LVDT-based position measuring system.

## Calibration Procedure

Before beginning the calibration procedure, allow the module to warm up for at least 15 minutes. On the front panel, there are three green LEDs positioned vertically and a red LED for power indication. The **POWER** LED normally glows steadily when power is applied and the signal conditioner module is in its *RUN* mode. When the module is in *RUN* mode (not in *CALIBRATION* mode), the green LEDs are on or flash to indicate failures, but in master/slave or standalone operation, the **P** LED on the master module will glow steadily. If the LEDs indicate a failure, calibration cannot proceed until the failure is corrected. When in *CALIBRATION* mode, the green LEDs indicate the position of the LVDT's core relative to its null point. To enter *CALIBRATION* mode, depress the **FULL SCALE** and **ZERO** buttons together until the red **POWER** LED starts flashing, indicating the module is now in *CALIBRATION* mode. The module can also be put into *CALIBRATION* mode by the **Cal** command via the RS-485 port. (See page 12 for the RS-485 commands).

## Null Point Location

After entering *CALIBRATION* mode from *RUN* mode, as described above, it is possible to find the LVDT's null point by moving the core and watching the green LEDs. In *CALIBRATION* mode, the three green LEDs operate according to Table 4 below as followings: if the core is far into LVDT's positive side (above null), only the uppermost (+) LED will glow. This means the core should be moved in the direction expected to be toward null. As the core approaches the null point, the center (0) LED will light at null. If the movement of the core is continued below null in the same direction, then the bottom (-) LED will glow. In this way, an LVDT's core can be positioned sufficiently close to the LVDT sensor's mid-range position for reasonably accurate calibration. **Note:** *The LVDT's core must not protrude from the LVDT during any null point measurement or else false null indications can result.*

Core Above Null (+)	Core At Null (0)	Core Below Null (-)
●	○	○
○	●	○
○	○	●

**Table 4** Finding an LVDT's null in *CALIBRATION* mode: LED state vs. LVDT core position

## Null Indicator Output

During *CALIBRATION*, the green front-panel LEDs are used to show the position of the LVDT's core in relation to its Null point. To find the Null point with better resolution, or for a continuous Null indication, connect an ungrounded DC voltmeter between terminals J4-1 and J4-2, the Null Indicator output. With the LVDT's core at Null, each terminal is floating at about 1.5 V DC above common ground, so the voltmeter will read zero volts between the terminals. As the LVDT's core is moved off Null, one terminal's voltage increases toward +3 V as the other terminal's voltage goes toward -3 V, or vice versa, when moving the core in the other direction, for a maximum voltmeter reading of approximately  $\pm 3$  Volts DC. *The LVDT's core must not protrude from the LVDT during any null point measurement or false null readings can result.*

## Setting the Full Scale Output Point

Once the LVDT core's Null position has been found and the core has been mechanically connected to the object whose motion is being measured, the next step is to calibrate the Full Scale output of the measuring system. This step assumes that the range of motion is symmetrical with respect to the LVDT's null point, but the process can work for asymmetrical measuring ranges, as long as the Full Scale and Zero points are no closer to each other than 10% of the sensor's full scale. This step assumes the module's Full Scale output was selected during the initial setup by setting DIP switch DS1 according to Table 2. Note that asymmetrical calibration could result in increased noise in the output due to bit flipping.

The red **POWER** LED should be flashing, indicating the unit is still in *CALIBRATION* mode. The core with its attached workpiece must be moved to the desired Full Scale (maximum travel) position. Once the core is in the Full Scale position, depress the **FULL SCALE** button on the front panel until the upper green LED below the **FULL SCALE** button flashes once, or send an **FS** command via the RS-485 port. The LED flash indicates that the Full Scale position calibration has been accepted. If an error occurred and it is desired to set the Full Scale again, depress the **FULL SCALE** button again and the Full Scale calibration will be updated with this new position as indicated by another flash of the upper green LED.

## Setting the Zero Output Point

When the Full Scale calibration is complete, the lower green LED above the **ZERO** push button will start flashing. Move the core with its attached workpiece to the Zero (travel start) position. Then depress the **ZERO** push button until the lower green LED flashes once, or send a **Z** command via the RS-485 port. The flash of the LED indicates that the Zero position calibration has been accepted. If an error occurred and it is desired to set the Zero point again, depress the **ZERO** button again and the Zero point calibration will be updated with the new position as indicated by another flash of the lower green LED.

Full Scale is set	Full Scale set required	Zero set required	Zero is set
●	☼	○	○
○	○	○	○
○	○	☼	●

**Table 5** LEDs in *CALIBRATION* mode. LEDs flash if a Full Scale reset or a Zero reset is required.

If the LVDT's calibration was successful and the DSP was able to be properly scaled, then the green LEDs will not be blinking. In the event that something unusual has caused the calibration to be rejected (such as a very high or very low output LVDT), either the upper (FULL SCALE) or lower (ZERO) LED, or both, may be flashing again. This means that the core must be moved to that particular position again and re-scaled or re-zeroed by repeating the original Full Scale and/or Zero calibration procedures. Normally, repeating the calibration process one time will remedy any problems that have developed during the DSP's auto-scaling operations.

When the calibration is completed, exit the *CALIBRATION* mode by depressing both the **FULL SCALE** and **ZERO** buttons simultaneously until the red **POWER** LED stops flashing and glows steadily. There is also an RS-485 command for exiting the *CALIBRATION* mode. After exiting *CALIBRATION* mode, the module will return to operation in *RUN* mode, the red **POWER** LED will glow steady, and the green LEDs will not be glowing, except for **P** of the master module in a master/slave configuration or as a stand-alone.

### Alternative Calibration Procedure

For some specific applications, there is an alternative calibration procedure that can often save time by establishing the mechanical relationship of the LVDT's core to the workpiece whose motion is being measured without going through the process of actually finding the LVDT's null point. This process can work well in cases where the nominal range of the LVDT is at least 10% larger than the range of motion of the workpiece to be measured. It works by connecting an ungrounded DC voltmeter with a range of 0 to  $\pm 3$  Volts to terminals J4-1 and J4-2, the Null Indicator Output. (Refer to **Null Indicator Output** on page 9)

Mechanically connect the LVDT core to the workpiece at about the middle of its range of motion. Move the workpiece to each end of its range of motion, noting the voltage indicated on the meter. Adjust the core's position relative to the workpiece so that the magnitude of the output of the voltmeter at each end of the range of motion is approximately the same, which establishes that the LVDT is operating in a symmetrical manner within its nominal range of measurement. Proceed to calibrate the system's Zero and Full Scale as noted on page 9. *The LVDT's core must not protrude from the LVDT during any of the measurements or calibration errors will result*

### Live Zero and Extra-range Output

When a unipolar DC output range is selected, the Full Scale and Zero positions correspond exactly to that range. But an S2A offers a "live zero" feature, whereby the DC output is able to go higher and lower than these end points by 2.5 to 3%. So, for example, with a 0-to-10 V full scale output, the output continues to respond past the Full Scale and Zero calibration points, going up to about 10.3 V or down to about -0.3 V. For current loop output, the output extends about 0.4 mA to 0.6 mA past the calibration points. For a 4-to-20 mA output (span = 16 mA), it continues to respond up to about 20.4 mA and down to about 3.6 mA. These extra-range values vary from module to module, depending on circuit and component tolerances.

### Using the Voltage and Current Outputs

When using an S2A module in any voltage output mode, the output current to the load resistor is normally just a fraction of a milliampere, but it should always be less than 5 mA. The recommended minimum load resistance across terminals J3-4 (+ output) and J3-3 (- ground) for any voltage output is 10,000 Ohms.

When using an S2A module's current loop outputs for 0 to 20 mA or 4 to 20 mA, the maximum permissible total loop resistance depends on the power supply voltage, as shown in Figure 5 below. When the module is powered by the recommended 24-Volt DC supply, the maximum loop resistance is 850 Ohms. **Important:** The S2A can only output loop current if the module output is connected to a load resistor. Failure to connect a loop load will result in the **E** and **S** LEDs flashing and error code **2048**. Typical loop load resistors are 250 or 500 Ohms, so the S2A module has adequate capacity for working with long connecting lines. Because an S2A's current output is 3-wire sourcing, it should **never** be connected **into a 2-wire loop-powered system**.

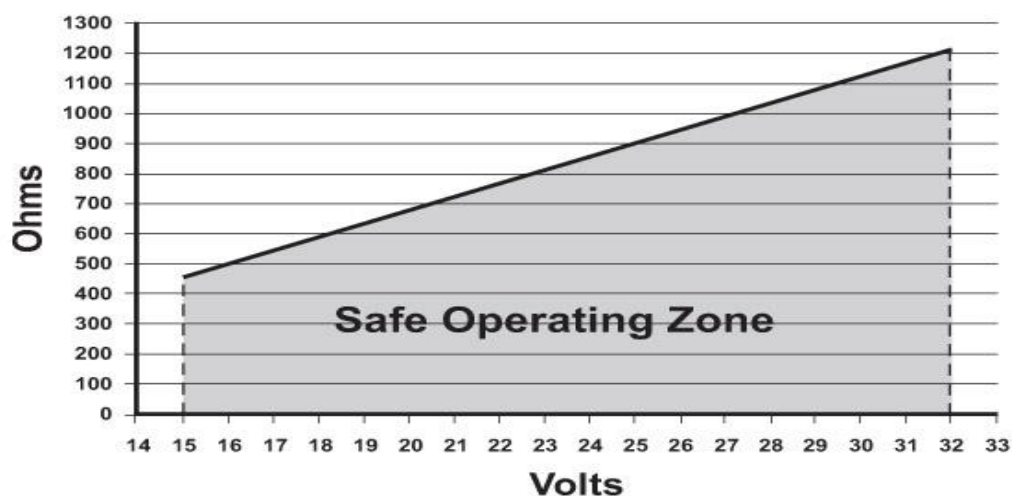

**Figure 5** Maximum Loop Resistance vs. Loop Supply Voltage

## Failure Diagnostics

The S2A module incorporates diagnostics to identify internal failures, mistakes made during the setup, and operational failures due to external causes, and to provide a failure indication both visually and electrically. When the S2A is in *RUN* mode, the front-panel LEDs indicate specific failures according to Table 6 by the LEDs steady on, by LEDs flashing at a rate of 0.1 second on and 0.1 second off, and by LEDs alternating between blinking and steady on.

<i>RUN</i> <i>MODE</i>	Normal Operation	Master Operation	Primary Open	Secondary Open	LVDT not Connected	Excitation Error	Shorted Sync	Frequency Set Error	Input Overload	Output Error
<b>POWER</b>	●	●	●	●	●	●	●	●	●	●
<b>P</b>	○	●	⊙	○	⊙	○	○	○	⊙	○
<b>E</b>	○	○	○	○	○	⊙	●	○	●	⊙
<b>S</b>	○	○	○	⊙	⊙	○	○	●	⊙	⊙

**Table 6** ⊙ indicates a flashing LED. Most failure modes flash the LEDs, but some LEDs stay steady on

In addition to the local visual indication of a failure or fault by the LEDs as illustrated in Table 6, the S2A also provides electrical outputs that allow the failure warning to be transmitted to a remote indicator, the system controller, or some other device. These electrical outputs include a failure signal using an open collector switch, an out-of-range analog output, and numerical error codes displayed over the RS-485 bus. A table identifying all the LED states and their diagnostic error codes appears in **Appendix A** on page 16.

Failures identified by the diagnostics incorporated in the S2A can be classified either as errors in setting up the module during installation that must be corrected before the S2A module can be calibrated, or an operational failure that occurs sometime after the module has been properly installed and put into service. There can be different error code outputs for each of these two types of failures, as shown in **Appendix A**. If an error code or failure is presented, it usually requires a "soft" reset to clear it, but occasionally might require powering the module down and back up ("hard" reset) to clear it. To initiate a soft reset on an S2A, depress the **FULL SCALE** button three times in a row for at least half a second each time, or enter the **Reset** command for that particular module's digital address over the RS-485 bus.

## Failure Warning Output Signals

Any operational failures shown in Table 6 will activate a failure warning output signal to an open-collector transistor switch to (+) power rated for 50 mA to operate a relay, alarm, or pull-up resistor for a TTL output pulse. This switch's factory default is normally closed (NC), but can be changed to normally open (NO) by the **Set FOP** RS-485 command. The failure warning signal has a short, programmable delay (default: 200 ms) before activation to eliminate trips due to noise spikes, a nearby lightning strike, or any similar transient. While set up errors shown in Table 6 are being corrected, the failure warning outputs can be deactivated using the **Errsig** RS-485 command toggled to OFF, or by holding down the FS button and then pressing the Z button two times in a row for at least half a second each. However, the failure LEDs will still be operating. When all setup errors have been corrected, a calibration can be done and the failure outputs should be reactivated using the **Errsig** command toggled to ON, or by repeating the procedure with the pushbuttons.

So an S2A will work with LVDTs having a low secondary DC resistance, the S2A's secondary short detector is disabled by default. To enable this function, hold down the FS button and press the Z button three times in a row for a half-second each time to toggle it ON, or use the command **Errsec on** over the RS-485 bus. If a secondary short develops, LEDs **E** steady on and **S** blinking will be displayed, along with error code 1024.

Besides the continuous output failure warning signal, the S2A module offers another electrical failure notification by driving the analog output to an out-of-range value of voltage or current. This out-of-range value is usually a slightly negative output, but in the case of the  $\pm 10$  V DC output, it goes to an output of about -11 Volts DC, and for the 4 - 20 mA output, the out-of-range value is slightly less than 2 mA. Fault indication by the out-of-range output will also be disabled when the **Errsig** command or procedure is used. Unlike the open collector failure output, the out-of-range output has no built-in delay. Typically the digital controllers used with redundant sensor systems sample the sensors' outputs at a fairly high rate and have built-in diagnostic software to reject any sensor's output that goes outside of the expected range of values.

## Troubleshooting LVDT Connections

Table 6 on the previous page shows that the S2A's front panel LEDs indicate most common LVDT wiring failures. If a front panel LED indicates an open winding, turn off the DC power and troubleshoot the LVDT wiring with an ohmmeter. Double check the LVDT's lead wire colors or connector pinouts against the specifications for that LVDT to be sure that all of the wires are correctly identified and properly connected.

When running cables between LVDTs and signal conditioners, a common wiring error is failure to properly connect the two secondaries together, separate from the other connections. For the S2A, the secondaries of the LVDT are connected together in a series-opposing configuration, so the module can operate on the net differential AC output that results from this winding connection. It is strongly recommended that the interconnection of the secondaries be done at the LVDT itself, before any cabling or wiring is attached, especially with a long cable run between the LVDT and the module. Normally the junction of the two secondaries is not connected to the signal conditioner, but if an S2A is to be hooked up in close proximity to a leaded LVDT, and if J2-1 is not being used for a shield ground point by jumpering J9, the secondary interconnection may be hooked up to J2-1 as a convenient tie point that is not connected to the module.

## Grounding and Shielding

The most common problem encountered with grounding and shielding of a sensor circuit is current flow in the ground circuit, called a ground loop. To avoid ground loops, a circuit must have only one common ground point. An S2A module's terminals J3-3 and J4-3 share the same common ground, so, to avoid ground loops, a single wire should be run to the system ground from just one of the ground terminals. The best practice is not to connect any sensor cable shield to the LVDT sensor's housing or to any separate or intermediate system ground point. Connect any sensor cable shields as simple Faraday shields only to the S2A's ground points at J3-3 or J4-3. If more convenient cable shield ground points are needed for an S2A operating from unipolar DC voltage (not  $\pm 15$  V DC), put the 2-pole shunt jumpers supplied onto J8 and J9 (located next to J2), which will convert J2-3 and J2-1 into additional ground points for sensor cable shields.

## Commands for the RS-485 port

Commands for transmission over the RS-485 communications link can be sent to an S2A from a PC using an ASCII terminal program like Hyper Terminal and a 2-wire RS-485 adapter from an RS-232 or USB port. The port adapter must be connected with the proper data polarity: (*D+*) to J3-1 and (*D-*) to J3-2. The port communication parameters are: 9600 bps, no parity, 8 data bits, 1 stop bit (9600, NP, 8, 1) with echo on and no flow control. Note that all commands must be preceded by a module address in the specific format: **Uxx(space)**, where **xx** is the numerical value, 00 to 15, of the module's decimal digital address as set with DS2 using **Appendix C** or by referencing the DIP switch settings shown on the left side label of the module.

**Note:** Some **Set** command descriptions show in bold face the range of values that follow the command and (*space*).

**Analog** In *RUN* mode, returns the nominal analog output value scaled in electrical units that depend on the setting of DS1, or the analog output range selected with the **Set Aout** command.

**Cal** Enters *CALIBRATION* mode; command is the same as pressing **FULL SCALE** and **ZERO** pushbuttons together.

**Clrall** In *RUN* mode, clears EEPROM of all RS-485 command settings used to override module DIP switch settings.

**Config** Lists the module's setup data and displays DIP switch settings and current EEPROM values. Specifically, it shows the module's firmware version, operating mode, digital address (00 - 15), date stamp, serial number, analog output setting (1 - 8), excitation frequency setting (0 - 3), output invert switch *off* or *on*, low frequency filter status (LF) *off* or *on* and filter corner frequency, excitation drive jumper (J7) *in* or *out*, failure output delay time (FD) and polarity (FOP) *NC* or *NO*, Lock status, and stored EEPROM values for ADC Lo, ADC Hi, Input pot, and Gain pot. (Log and store all **Config** data and values by digital address to be able to reconfigure a hot swapped module at a later time).

**Error** In *RUN* mode, displays any setup or operations error code(s); for multiple errors, error code sum is displayed.

**Errsec** In *RUN* mode, **ON**, **OFF** (*default*) toggles error indications and failure outputs due to low DCR secondaries.

**Errsig** In *RUN* mode, **ON** (*default*), **OFF** toggles error indications and failure outputs for all errors found during setup.

**Exit** Required to exit *CAL* mode, or to exit any **Set** command writing a value to the module's EEPROM in *RUN* mode.

**FS** In *CAL* mode, sets the module's full scale output point at the LVDT core's maximum position and is the same as pressing **FULL SCALE** pushbutton. Occasionally it may require setting a second time after using the **Z** command.

**Help** Shows all user commands available for execution over the RS-485 bus, including a few not shown in this list.

**LEDs** In *RUN* and *CAL* modes, outputs the status of the 3 green LEDs, displayed in **S-E-P** order, e.g.: - \* **0** means **S** LED is off, **E** LED is flashing slow, and **P** LED is on. + is a fast flash and ! indicates alternating solid and flashing.

**Lock** In *RUN* mode, locks the module against any changes and displays attempted tampering over the RS-485 bus.

**Null** In *RUN* mode, displays the Null Output voltage at any core position and is typically used to verify that the core of an LVDT is at null; may also be used to establish the symmetry of an LVDT's endpoint outputs versus core position.

**Read LF** In *RUN* mode, when DS2-4 is *ON*, or the LF filter is invoked, shows the status and frequency setting of the supplemental low pass filter.

**Recal FS** In *RUN* mode, after a calibration has been completed, if the actual full scale output value is within  $\pm 5\%$  of the nominal full scale output value selected by DS-1 or the **Set Aout** command, this command trims the actual full scale output value to match the selected full scale output value. The command may be repeated once to get the most precise FS output value. Recal can be set at module by pressing **FULL SCALE** button until the **POWER** LED blinks.

**Recal Z** In *RUN* mode, after a calibration has been completed, if the actual zero output value is within  $\pm 5\%$  of the nominal zero output value selected by DS-1 or the **Set Aout** command, this command trims the actual zero output value to match the selected zero output value. This command may be repeated once to get the most precise zero output value. Recal can also be set at the module by pressing the **ZERO** pushbutton until the **POWER** LED blinks.

**Reset** In *RUN* mode, produces a "soft" reset of the module's processor so the module restarts as if it is powering on. Command is the same as pressing the **FULL SCALE** pushbutton three times for at least one-half of a second each.

**Reset All** In *RUN* mode, using prefix **U90** instead of **Uxx**, this command performs a simultaneous "soft" reset on all modules connected to the RS-485 bus. Each module on the RS-485 bus then restarts itself as if it is powering on.

**Restore** In *RUN* mode, resets module to factory set condition by cancelling all user setup values stored in EEPROM. It can also be invoked by pressing the **ZERO** pushbutton three times in a row for one-half of a second each time.

**Set ADC Hi** In *RUN* mode, writes an A/D converter high value into module's EEPROM. Command is used during a hot swap module reconfiguration to enter the ADC Hi value logged from the original module's **Config** command.

**Set ADC Lo** In *RUN* mode, writes an A/D converter low value into module's EEPROM. Command is used during a hot swap module reconfiguration to enter the ADC Lo value logged from the original module's **Config** command.

**Set Aout** In *RUN* mode, permits setting the analog output range: **1 - 8**, independent of the setting of DIP switch DS1.

**Set Exf** In *RUN* mode, permits setting excitation frequency: **0 - 3**, independent of settings of DIP switches DS2-1, -2.

**Set FD** In *RUN* mode, permits the user to set the delay time before the failure warning output switch is activated from 0 to 900 msec in 100 msec increments: **0 - 9**. The factory default delay time is set at 200 msec.

**Set FOP** In *RUN* mode, sets failure warning switch polarity: **NC**, Normally Closed (*default*) or **NO**, Normally Open.

**Set Gain** In *RUN* mode, writes a Gain pot value into module's EEPROM. Command is used during a hot swap module reconfiguration to enter the Gain pot value logged from the original module's **Config** command.

**Set In Pot** In *RUN* mode, writes an Input Pot value into module's EEPROM. Command is used during a hot swap module reconfiguration to enter the Input Pot value logged from the original module's **Config** command.

**Set Inv** In *RUN* mode, permits inverting analog output by overriding setting, **ON**, **OFF**, of invert DIP switch DS2-3.

**Set LF** In *RUN* mode, sets the corner frequency of the supplemental low pass filter between 0.1 Hz and 10 Hz. If DS2-4 is not *ON*, command permits LF filter status to be changed: **ON**, **OFF**, and its corner frequency to be set.

**Ver** In *RUN* mode, returns the version number of the module's firmware.

**Z** In *CAL* mode, sets the module's zero output point at the minimum position of the LVDT's core; function is the same as pressing the **ZERO** pushbutton. Occasionally it may require setting a second time after using the **FS** command.

## Endpoint Recalibration Process

In certain circumstances, it may be desirable to perform a "hot" recalibration on a module, typically from the effects of thermal expansion and/or contraction on a mechanical system. Recalibration permits trimming of either end point's analog output in a system that is already calibrated, provided that the actual output values from the module are within  $\pm 5\%$  of the full span of the output chosen by the setting of DS-1 or the **Aout** command. Recalibration can be used to trim either end point's analog output independent of the other and is done while the module is operational, so it has an immediate effect upon the system's analog output. Recalibration can be done with one of two RS-485 commands, **Recal FS** and **Recal Z**, or by depressing the **FULL SCALE** or **ZERO** buttons until the **POWER** LED flashes once.

Before proceeding to perform a recalibration, verify that the difference between the actual output value at the end point to be trimmed is within  $\pm 5\%$  of the span of the analog output for which the module was set, where the span is the difference between the maximum and minimum values of the selected analog output. Thus, the trimmable range of actual output at the system's Zero point is -5 to 5% of the span, and at the Full Scale point, it is 95 to 105% of the span. If the analog output at an end point is not within the limits noted, the attempt at recalibration will not be effective. Recognize that if the directional sense of the LVDT has been inverted by turning on S1-3, the actions of the **FULL SCALE** or **ZERO** pushbuttons are also inverted.

To perform a recalibration, move the workpiece to the end point to be recalibrated and invoke the **Recal** command for that end point over the RS-485 bus, or depress and hold down the button for that end point until the **POWER** LED flashes once. Repeating the process once is permissible, but not more than once.

## Hot Swapping Modules

An S2A module connected in a multi-module array can be "hot swapped" with another S2A module having the same internal DIP switch and jumper settings, and having values loaded in specific EEPROM locations that match those in the original module. Carefully done, this process can make the replacement module's characteristics match those of the module being taken out of service within approximately 1% and will also allow the remaining modules in the array to continue operating in a normal manner.

To prepare the replacement module for a hot swap, the configuration data of the original module, which should have been obtained previously and saved for a possible hot swap, is needed. If this data is not available, connect to the RS-485 port of the original module with a PC and terminal program, and use the **Config** command to get it. Using that data, set the internal DIP switches and jumpers of the new module to match, then power it up and use its RS-485 port as noted above to load the "standardized" values of ADC Hi, ADC Lo, In Pot, Gain, and any values for FOP, FD, LF, Aout, Exf, and Inv, using their **Set** commands.

To perform a hot swap, first shut down the positive power input connected to J4-4, the red plug, from the original module, which may be done by pulling the power fuse, or tripping the circuit breaker, or switching off the power switch for that module, or by loosening the screw terminal of J4-4 and carefully removing the wire. Do not remove the red plug itself with any power present. Once the unit has been depowered, the plugs may be disconnected from the original module in order of: J4 (red), J3 (green), J2 (blue), then J1 (black). Reverse the sequence to plug back into the replacement module. Finally, reconnect positive power.

## Replacing an S1A Module with an S2A Module

To hot swap an S1A with an S2A, insert the shunt jumper (supplied) over J201 (near the center of the pcb) to invoke the S1A emulation mode of the S2A replacement module. In this mode the module will operate in the manner of an S1A. If the S1A is operating a half-bridge, move J10 over to its half-bridge position. Follow the instructions above for DIP switch setup and to load the configuration data from the original S1A. Then follow the de-powering and re-powering instructions. Note that the plugs and wiring from the S1A can be utilized with the S2A in S1A mode, so no rewiring should be necessary. One additional note: the default failure warning output for an S1A is Normally Open, but for an S2A it is Normally Closed. If the module's failure output switch polarity needs to be changed, refer to the **Set FOP** RS-485 command.

Although the system can be operated in S1A emulation mode indefinitely, the module match may not be ideal, so for optimum performance, when a suitable opportunity presents itself, the new module should be restored to S2A mode by removing the shunt jumper on J201 and the system should be calibrated again.



## S2A Specifications

Operating power:	+15 to +30 V DC (+24 V DC nominal), 100 mA maximum at 24 V DC; +15 V DC and -15 V DC needed for $\pm 10$ V DC bipolar output
LVDT Excitation voltage:	3.0 Vrms (nominal) push-pull drive (factory default) 4.5 Vrms (nominal) push-pull drive (jumper J7 removed) 1.5 Vrms (nominal) single-ended drive for low impedance primary
Excitation frequencies:	1 kHz, 3 kHz, 5 kHz, 10 kHz (nominal)
Auto-master syncing:	Master output couples up to fifteen slave inputs; if original master fails, new master is automatically generated for fail-safe excitation control.
LVDT AC output range:	50 mVrms to 5000 mVrms at LVDT's full scale position
Analog DC outputs:	0 - 5 V, 1 - 5 V, 0.5 - 4.5 V, 0.5 - 9.5 V, 0 - 10 V, -10 to +10 V, 0 - 20 mA 3-wire sourcing, 4 - 20 mA 3-wire sourcing
Loop resistance:	850 Ohms maximum with 24 V DC supply
Output non-linearity:	$\leq \pm 0.025\%$ of Full Span Output (FSO)
Frequency response:	Standard -3 dB BW: 10% of excitation frequency (minimum) Low noise -3 dB BW: 0.1 - 10 Hz (default), user settable
Noise and ripple:	$\leq 1$ mVrms (voltage output), or $\leq 2$ $\mu$ Arms (current output)
Fault detection:	Open or shorted LVDT winding, open, shorted, or grounded LVDT connection, LVDT cable disconnected, open or shorted analog output
Fault indication/output:	Flashing LED's; analog output driven out of range; 50 mA open-collector solid state switch, user settable to NC (default) or NO
Null indication:	Front panel LEDs, $\pm 3$ V DC max. floating null output signal
Operating temperature:	-20 to 75 C
Temperature coefficient:	$\pm 0.002\%$ of FSO/ $^{\circ}$ C (combined span and zero shifts)
Zero set:	Front panel push button or RS-485 ASCII command
Full Scale set:	Front panel push button or RS-485 ASCII command
Digital interface:	RS-485 2-wire multi-drop network, 16 individual addresses

## S2A Module Outline Dimensions

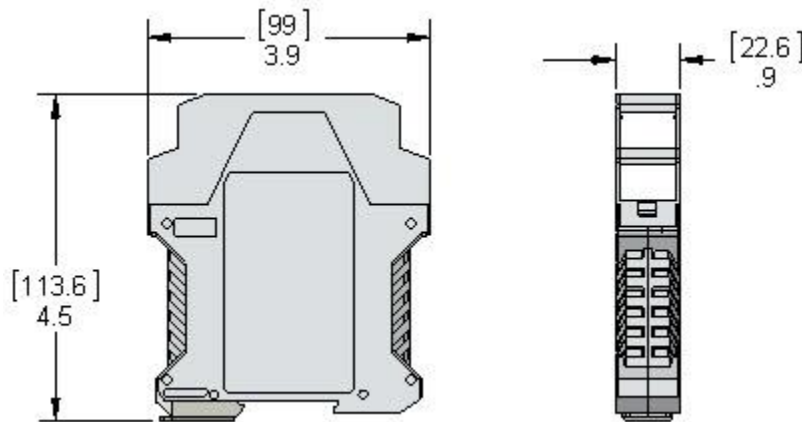

## Appendix A: S2A Error Codes and Fault Matrix

LED display	Code	Error / Fault	Description / Diagnosis	Setup Errors		Operating Faults	
				Analog Fault Output	Failure Warning Output	Analog Fault Output	Failure Warning Output
<b>P, E, S,</b> and <b>POWER LEDs</b> in <i>RUN</i> Mode	RS-485 Error Code						
<b>P</b> blinking	1	LVDT primary circuit open	Open circuit in LVDT primary or its wiring	yes	yes	yes	yes
<b>P</b> alternates blinking with steady on	1	Open LVDT primary circuit on master module	Open LVDT primary circuit or wiring on master module	yes	yes	yes	yes
<b>S</b> blinking	2	LVDT secondary circuit open	Open circuit in LVDT secondary or its wiring	yes	yes	yes	yes
<b>P</b> and <b>S</b> both blinking	3	LVDT not connected	LVDT not connected	yes	yes	yes	yes
<b>P</b> alternates blinking with steady on and <b>S</b> blinking	3	LVDT not connected to a master module	LVDT not connected to a master module	yes	yes	yes	yes
<b>E</b> blinking	4	LVDT excitation signal drops low	Excitation level drops low due to overload from low LVDT primary impedance	yes	yes	yes	yes
<b>E</b> alternates blinking with steady on	8	No excitation signal to LVDT	No excitation signal detected; possibly a primary short circuit or misconnection	yes	yes	yes	yes
<b>E</b> alternates blinking with steady on	16	Loss of LVDT excitation signal	No excitation signal detected; internal failure of excitation generator	yes	yes	yes	yes
<b>S</b> steady on	32	Excitation frequency error in slave module	Slave DIP switch setting different from master's DIP switch setting	yes	yes	n/a	n/a
<b>E</b> steady on	64	Sync bus for slave modules has short circuit	No sync pulse detected on sync bus pin of slave modules upon startup.	yes	yes	n/a	n/a
<b>E</b> and <b>S</b> both steady on	128	Sync pulse timeout error	Sync start pulse not detected on bus after specified elapsed time	yes	yes	n/a	n/a
<b>E</b> blinking and <b>S</b> steady on	256	External syncing frequency mismatch	External sync frequency outside range of current DIP switch setting	yes	yes	n/a	yes
<b>E</b> steady on and <b>S</b> blinking	1024	Short on LVDT output signal	LVDT secondary shorted across or to ground	yes	yes	yes	yes
<b>E</b> and <b>S</b> both blinking	2048	Analog output connection fault	Loop open in current mode; output short in voltage mode	yes	yes	yes	yes
<b>P</b> and <b>S</b> both blinking and <b>E</b> steady on	4096	LVDT input overload error; calibration error	LVDT output overdriving system; new calibration required	yes	yes	yes	yes
<b>P, E,</b> and <b>S</b> green LEDs all blinking	8192	Alert of attempted tampering with a locked module	Response to a tampering attempt involving a locked module	no	no	no	yes

**Note 1:** In a master/slave connection, the master module will show **P** steady on along with an error LED display.

**Note 2:** RS-485 error codes that result from multiple faults are additive; e.g.: error code 128 combined with error code 16 results in an error code 144 response to a **CONFIG** or **ERROR** command sent over the RS-485 bus.

## Appendix B: Cybersecurity Features of the S2A Module

Because Alliance Sensors Group’s model S2A LVDT signal conditioner module is a microprocessor-based electronic product, power plant users are naturally concerned about potential vulnerabilities to any type of cyberattack. For this reason, all S2A modules have been equipped with significant cybersecurity features. Foremost of these is the fact that there is no physical or electronic connection to the Internet. While there is an RS-485 communications port built into an S2A module for diagnostic purposes, it has absolutely no access to the operating firmware of the module, so the module cannot be subverted by attempts to access its operating system. In this manner it is protected at the highest level from any malevolent cyberattacks.

However, the S2A module does permit certain operational parameters to be adjusted by ASCII commands transmitted over the RS-485 bus. To prevent tampering with any of the operating parameters that were set up when it was installed, the S2A offers a lock feature that prohibits any tampering with the module’s setup and can notify the control room operator of any attempt to tamper with the module. This lock feature can be initiated over the RS-485 bus with the appropriate command, or it can be physically set at the module by using the locking process noted below. In either case, the module cannot be unlocked over the RS-485 bus. It can only be unlocked and reset by an authorized person who has been instructed in the specific unlocking process that must be applied to the module itself. Thus, this person must be someone who has already been cleared by security and who is present inside the facility.

This lockout approach to cybersecurity puts the emphasis on the facility security systems and personnel. Most users in the power generation industry already have substantial security safeguards in place, so this approach is unlikely to place any extra burden on either the power plant’s security systems or personnel.

### Applying the Lock Code to an S2A Signal Conditioning Module

One way the lock feature of an S2A can be applied is by invoking the **Lock** command over the unit’s RS-485 port, using the syntax shown on page 12. There is no bus-wide ASCII **Lock** command, so each S2A module must be locked separately. The other method of applying the lock feature is done at each module itself by depressing and holding down the **ZERO** pushbutton on the S2A’s front panel and simultaneously depressing the **FULL SCALE** pushbutton three times in a row for at least 0.25 seconds each time. When lock takes effect, the **POWER** LED will flash once, indicating that the lock has been engaged. When an S2A is locked, it will still respond to informational data commands such as **Config, Analog, Ver**, etc., but will react to transformational commands or actions such as **Recal, Set, Reset, Cirall**, etc., as tampering. If anyone tries to tamper with a locked module, the green front panel LEDs will flash continuously, a tamper alert will be sent to the failure warning switch, and tamper code 8192 will be output onto the RS-485 bus. It is important to note that the correction of any errors exhibited by the module require the lock to be removed.

### Applying the Unlock Process to a Locked S2A Signal Conditioning Module

As was noted above, an S2A module that has been locked can only be unlocked by someone applying the unlocking process directly to the locked module. There is no RS-485 command for the unlocking process. Furthermore, any attempt to unlock the module without going through the unlocking process will trigger a tampering alert. The unlocking process is the same as the locking process applied at the module itself by depressing and holding down the **ZERO** pushbutton on the front panel and simultaneously depressing the **FULL SCALE** pushbutton three times in a row for at least 0.25 seconds each time. On the second push of the **FULL SCALE** button, any tampering alert will be discontinued. On the third push, the unlocking action will take effect and the red **POWER** LED will flash once, indicating that the module’s lock has been released.

## Appendix C: DIP Switch DS-2 Settings Table for Decimal Digital Addresses

Digital Address	00	01	02	03	04	05	06	07	08	09	10	11	12	13	14	15
DIP switch <b>DS2-5</b>	OFF	OFF	OFF	OFF	OFF	OFF	OFF	OFF	ON	ON	ON	ON	ON	ON	ON	ON
DIP switch <b>DS2-6</b>	OFF	OFF	OFF	OFF	ON	ON	ON	ON	OFF	OFF	OFF	OFF	ON	ON	ON	ON
DIP switch <b>DS2-7</b>	OFF	OFF	ON	ON	OFF	OFF	ON	ON	OFF	OFF	ON	ON	OFF	OFF	ON	ON
DIP switch <b>DS2-8</b>	OFF	ON	OFF	ON	OFF	ON	OFF	ON	OFF	ON	OFF	ON	OFF	ON	OFF	ON