

COMPUTER GENERATED DOCUMENTATION MAKE NO REVISIONS I		
REV	DESCRIPTION	DATE
A	PRODUCTION RELEASE	11/16/2011

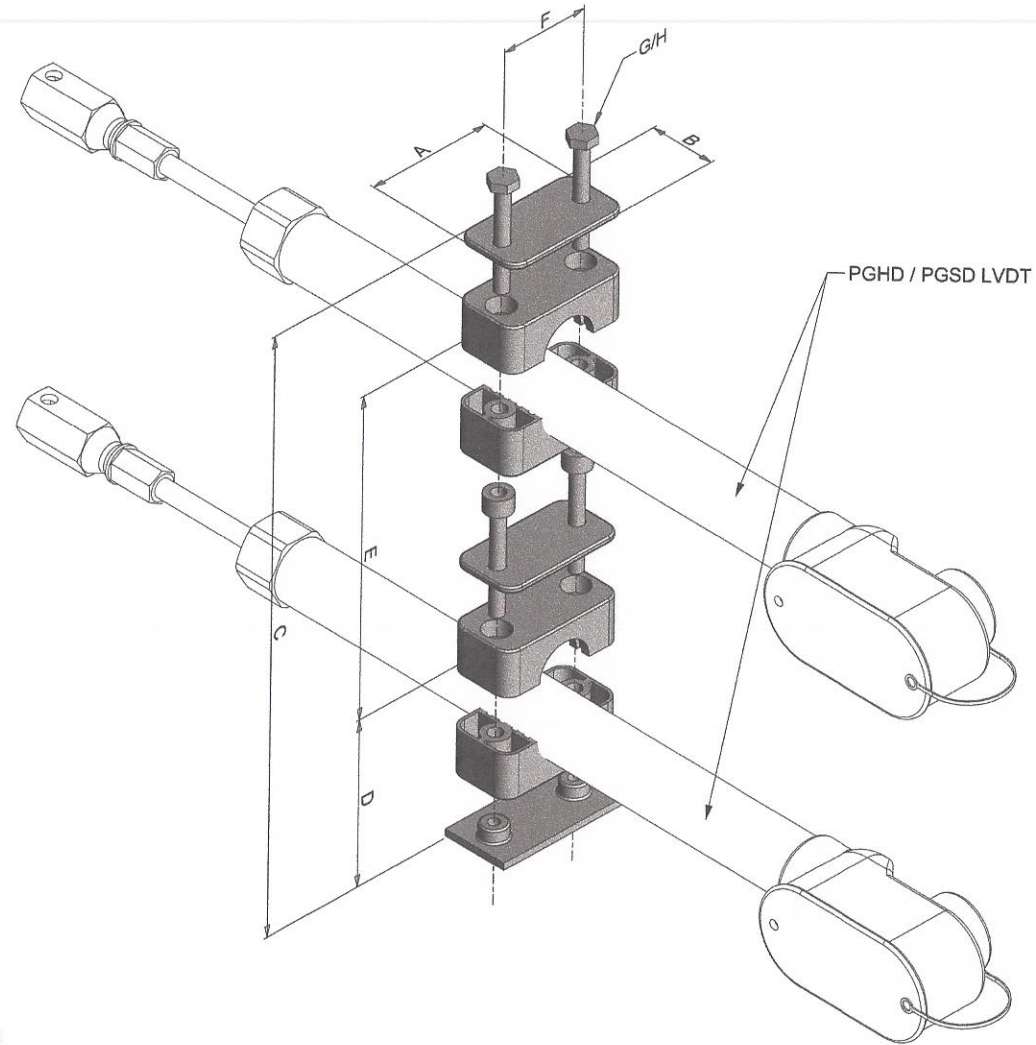

- NOTES:
 NOTE 1: METRIC DIMENSIONS IN MILLIMETERS ARE IN PARENTHESES
 NOTE 2: N/A MEANS NOT APPLICABLE OR APPROPRIATE TO MOUNTING
 NOTE 3: HEIGHT DOES NOT INCLUDE MOUNTING SCREW HEAD HEIGHT
 NOTE 4: METRIC SCREW SIZE IS ALTERNATIVE, NOT EXACT EQUIVALENT

DIMENSION IDENTIFICATION		A	B	C	D	E	F	G	H
DESCRIPTION	LVDT TYPE	LENGTH	THICK	HEIGHT	CENTER HEIGHT	CENTER CENTER	MOUNTING CENTER	SCREW SIZE	SCREW LENGTH
STAUFF DUAL STACKED O/U	PGHD	2.32 (59)	1.18 (30)	3.66 (93)	0.945 (24)	1.77 (45)	1.57 (40)	1/4-20 (M6)	1.62 (42)
	PGSD	2.80 (71)	1.18 (30)	4.92 (125)	1.26 (32)	2.40 (61)	2.05 (52)	1/4-20 (M6)	2.38 (67)

<p>UNLESS OTHERWISE SPECIFIED DIMENSIONS ARE IN INCHES TOLERANCES ARE:</p> <p>DECIMAL ANGLE X.XX = ±0.01 ±0° 30' X.XXX = ±0.005</p> <p>DUAL DIMENSIONS 1.00in (25.4mm)</p> <p>NEXT ASSY</p> <p>USED ON</p>	PROPRIETARY NOTICE INFORMATION CONTAINED IN THIS DOCUMENT IS THE PROPERTY OF EVERIGHT SENSORS. DO NOT DISTRIBUTE OR COPY WITHOUT WRITTEN PERMISSION.		TITLE: GENERAL ASSEMBLY DRAWING STAUFF DUAL STACKED O/U	
	APPROVALS	DATE	DWG NO. OU SERIES KIT	
	DRAWN: JSB	11/16/11	SIZE	REVISION
	CHECKED:		C	A
APPROVED:		Scale = 1:3/4		
DO NOT SCALE DRAWING		Sheet 1 of 1		